

SHARP

前置式洗衣機

ES-FH8BH-W

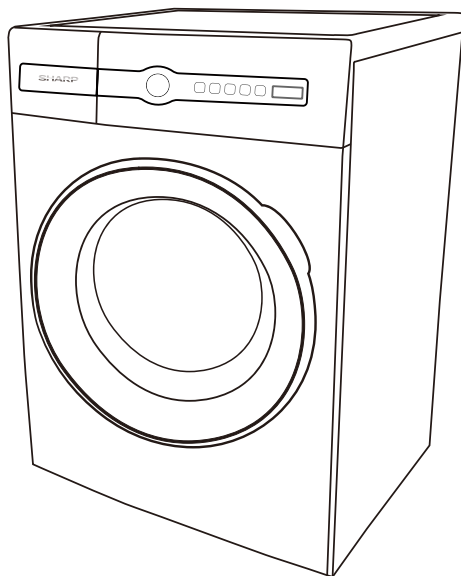

使用說明書

感謝您購買本產品。

使用本產品之前，請仔細閱讀本使用說明書和安全注意事項。

請妥善保管本使用說明書。

本產品專為家用設計。

目錄

使用洗衣機前

安全注意事項	CN-2
安裝	CN-4
部件名稱	CN-10
配件	CN-10

操作

產品規格	CN-11
機門上鎖/解鎖	CN-12
洗滌劑盒	CN-13
控制面板	CN-14
程序表	CN-16
其他選項和功能	CN-20

清潔與保養

清潔與保養	CN-21
問題和解決方案	CN-23
錯誤訊息說明	CN-24



安全注意事項

■ 為保護使用者及他人的健康和財產安全，請務必遵守以下安全注意事項。





警告

為正確操作，使用洗衣機前請仔細閱讀本部分內容。

● 對於無視標誌內容而採取錯誤的使用方法可能造成的危害和損害程度，此處的注意事項分為“警告”和“注意”兩類，並按照以下的標誌分別進行說明。

 警告	此標誌表示不按照說明書操作有導致重傷或死亡的可能。
 注意	此標誌表示不按照說明書操作可能會對產品造成輕微損傷或破壞。

		
此標誌表示警告或注意的內容。	此標誌表示禁止行為。	此標誌表示需執行的強制動作。

 警告	
<p> ●若電器損壞時，必須由本公司維修人員或具有相關資質的專業人員加以更換，否則可能會導致觸電、失火或受傷。</p>	<p>●因本洗衣機配有雙極接地插座的電線，盡可能使用漏電保護器。 避免漏電以防受傷。</p> 
<p>●必須乾手拔掉插頭，否則可能會引起觸電。</p>  <p style="text-align: center;">禁止用濕手</p>	<p> ●請使用與插頭配套的特殊電壓和電流的單頭插座。與其他電器共用插座易造成電器過量使用，可能會導致火災。</p>
<p>●請勿使用損壞或鬆動的電源線或插頭，否則可能會導致觸電、短路或起火。</p> 	<p> ●當插頭或插頭底座周圍有污垢時，請徹底擦拭電源線插頭。 無污垢 否則可能導致起火。</p>
<p>●請勿破壞電線。請勿損壞或強行彎折、拉攏或處理電線。電源線請勿受重壓。 電源線損壞可能會引起觸電或火災。</p>  <p style="text-align: center;">禁止</p>	<p>●洗衣機不宜安裝在潮濕處或室外等受日曬雨淋的場所。 否則，可能會引起漏電，從而導致觸電或失火。</p>  <p style="text-align: center;">禁止</p>
<p>●維修過程中，洗衣機請勿碰水，否則可能會導致短路或觸電。 可能會導致短路或觸電。</p>  <p style="text-align: center;">禁止</p>	<p>●請勿靠近蠟燭、蚊香、煙頭及其他明火。為避免由鎖具損壞造成受傷。</p>  <p style="text-align: center;">禁止</p>
<p>●請勿將汽油、酒精、稀釋劑或沾有這些污漬的衣物放入或靠近洗衣機。 為避免起火、爆炸帶來的傷害。</p>  <p style="text-align: center;">禁止</p>	<p>●氣體洩漏時，請勿操作本機。</p>  <p style="text-align: center;">禁止</p>

警告

- 請勿讓兒童靠近洗衣籃，請勿把盒子或架子放在洗衣機旁。
兒童有掉入洗衣籃受傷的可能。

本設備不預期供生理、感知、心智能力、經驗或知識不足之使用者（包括兒童）使用，除非在對其負有安全責任的人員之監護或指導下安全使用。

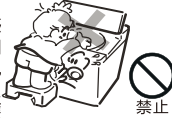

- 玻璃門在高溫洗滌過程中會變熱，機器運作時，請勿觸摸玻璃門，請勿讓兒童靠近。
- 如果需要在高溫洗滌過程中開門，請等待溫度降低至安全標準，門會自動解鎖。
- 包裝材料可能會對兒童造成危險，請勿讓兒童靠近所有包裝材料（塑膠袋、保護物料等）。



注意

- 拔掉電源時不要拉扯電源線。

否則可能會導致觸電、短路、起火。



- 長時間不使用本機時，請拔掉插頭。
本機塑膠件變形可能導致觸電或漏電。



- 維修時必須乾手拔掉電源線。
否則可能會導致漏電，造成受傷。



- 如果電源線損壞，為避免危險，請聯絡製造商或其他服務機構的具有相關資格人員及時更換。

- 請勿用50°C以上的水進行洗滌。

本機塑膠件變形可能導致觸電或漏電。



- 請勿清洗、漂洗和脫水防水布。

禁止放入睡袋、雨衣、滑雪罩、防塵罩、自行車套和車套等。否則可能會在脫水中激烈振動或翻倒而導致傷害，或導致本設備機體、牆壁、地板等的損傷。

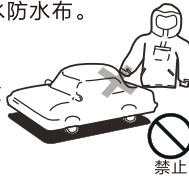

- 請勿站在本機頂部或將重物放在本機頂部。

否則可能會引起變形，並造成傷害。



- 需要兩個人搬運或運輸。

- 洗衣機工作時，請勿接觸洗衣機底部。機器運行中的部件產品可能會造成傷害。



- 清洗前請打開水，檢查供水軟管連接。防止因鬆動或沒有旋緊而可能漏水造成損壞。



- 使用新軟管時，不應再重複使用舊軟管。

- 當在鋪有地毯的地板上安裝洗衣機時，地毯不要堵塞洗衣機底部的通風口。



漏水

- 供水軟管應旋緊在機組上。

否則可能會導致漏水。長時間使用，機組可能會因連接螺栓鬆動而導致漏水。請及時檢查並再次旋緊。



- 不使用本機時，請關掉水龍頭。防止因漏水造成的損壞。



安裝

打開洗衣機包裝

注意：非常重！

- 搬運此機器時，需要多人搬運或機械輔助。
- 在運輸過程中，盡量保持洗衣機直立。

- 為防止運輸損壞，本產品已進行包裝。請除去滾筒內部和洗衣機四周的所有包裝材料。
- 請將原包裝盒和包裝材料保存在安全的地方。如果將來需要運輸本機，可以防止機體損傷。另外，在不使用本機時，可使用紙箱來儲存。如果丟棄紙箱，請盡可能回收所有包裝材料。
- 塑膠包裝對嬰兒和幼兒易造成窒息危險，需確保所有的包裝材料存放在遠離嬰幼兒的地方，並安全處理。
- 搬動洗衣機須小心，並移除底部包裝。確保底座保護裝置與底部件一起拆除。如果沒有拆除，請將本機側放，再手動從本機底部取出保護物料。
- 拆下固定電線和排水軟管的膠帶。
- 從滾筒上拆卸所有附件。

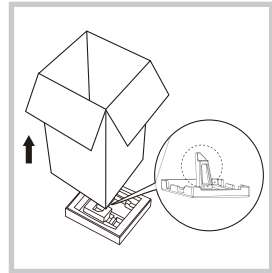

檢查包裝內容

- 檢查包裹的所有部件，並確保已收到所有配件。
- 檢查洗衣機是否因運輸而損壞。將電源線拉直，檢查是否有損壞。如果機器或電源線已損壞或不能正常工作，請勿使用機器。如果產品損壞或遺失，請與我們的售後服務中心聯絡，以獲取檢查、維修或退貨的建議。
- 請閱讀本手冊，並熟悉洗衣機的所有部件及操作原理。請特別注意前幾頁的安全注意事項。

操作要求

- 請勿在洗衣機正常工作溫度（0–40℃）以外的環境下操作洗衣機。在低於0℃的溫度下使用可能會損壞機器的進氣閥和排水系統。
- 如果洗衣機存放在0℃以下的地方，在使用前應將其轉移到環境溫度較高的地方，並確保軟管和水管中無殘留的凍水。
- 本產品只供私人家庭使用。它不適用於商業、工業或貿易用途。

安裝

選擇位置

安裝設備前，請確保安裝位置滿足以下要求：

- 地面堅硬、乾燥、平整，如不平整，請調整底腳（見第CN-6頁）。
- 不受日曬雨淋及其他天氣影響。
- 通風良好。
- 四周牆壁與本機最突出部分之間有100mm的空間。
- 室溫 $\geq 0^{\circ}\text{C}$
- 距離熱源不小於200mm。
- 確保本機外殼與外部熱源（如裝有發熱功能的設備）之間至少有200mm的距離。
- 請勿壓住電源線。
- 地面無地毯（如無法避免，請在本機下方放置塑膠墊），並確保地毯沒有阻塞底座上的任何通風口。
- 安裝表面：本洗衣機必須安裝在平坦、均勻、堅硬的地面上，以免在使用或維護過程中翻倒。請勿安裝在地毯上。如果機器必須安裝在地毯上，請在機器下方放置塑膠墊，並確保地毯沒有阻塞底座上的任何通風口。

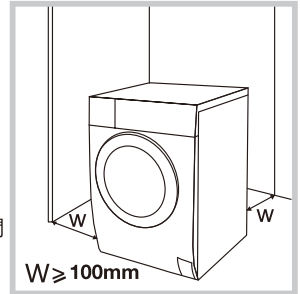

請勿安裝設備：

- 在可鎖門、可滑動的門或背後有門鏈的後面，在此種情形下，會限制機門完全打開。
- 在密封櫃裏。

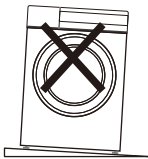

1. 傾斜的地面

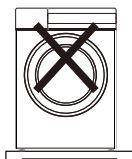

2. 平臺和支架上

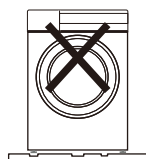

3. 凹凸不平的地面

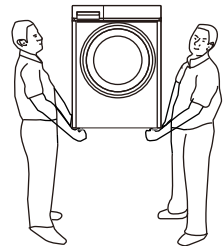

運輸

本機需要兩個人搬運。

搬運時，兩人需分別托住兩側機器的底腳。

安裝

拆卸運輸螺栓

為在運輸時保護滾筒，本機背面裝有四個運輸螺栓，使用前須將其全部拆除，否則脫水時會出現強烈振動、噪音和功能異常。

1. 請用扳手鬆開四個運輸固定用螺栓。
2. 將螺栓左右晃動後拔出。
3. 使用提供的塑膠蓋對準孔的位置按進去，直到吻合為止。

—讓銷售人員或專業維修人員安裝機器。

—請妥善保管好拆卸下來的運輸固定用螺栓，如果需將本機移至其他地方，您將再次需要使用它們。

—如圖所示，在使用前請務必確認底座保護裝置沒有卡在洗衣機底部，否則會影響洗衣機的正常使用的。

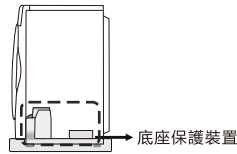
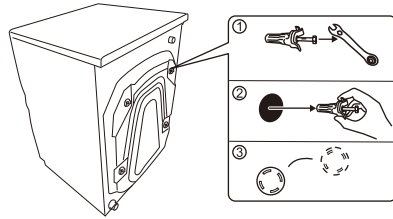

調整水平底腳

洗衣機安裝不平，使用時可能會出現異常噪音、震動或功能異常。請調整水平底腳，使本機處於水平位置。

方法如下：

1. 用鉛垂線檢查洗衣機是否安裝在水准地面上，如下圖所示。
 - 如果洗衣機的框架線與鉛垂線平行，則洗衣機處於水准地面。
2. 如有必要，調整洗衣機的調整腳，使洗衣機處於水平位置，如下圖所示。
3. 將雙手斜放在洗衣機上，輕輕按壓和晃動洗衣機，以確保洗衣機安裝平穩。

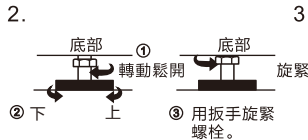
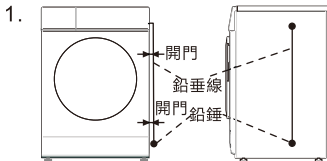

安裝

連接進水管

1. 檢查密封墊圈是否固定牢固。
2. 將軟管的彎曲端連接到洗衣機的進氣閥上，旋緊連接螺栓。
3. 將軟管連接水龍頭，然後旋緊連接螺栓。
4. 開啟水龍頭，檢查是否漏水。如果發現漏水情況，請旋緊連接螺栓。如果水壓很大，請關好水龍頭，然後慢慢開啟。

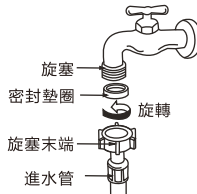

注意事項：

- 不要使用溫度超過50℃的水。
- 不要連接熱水供應。
- 如果水龍頭不合適，請諮詢經銷商。

在洗衣機上安裝供水管

握住供水管，順時針旋轉螺栓，直至螺栓旋緊。

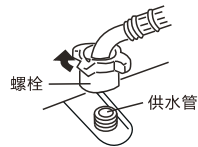

需要拆卸供水管時，關閉水龍頭後逆時針旋轉螺栓。

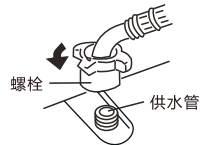

安裝

防鼠蓋板安裝

注意：

- 安裝前請拆下運輸固定用螺栓，安裝至少需要兩人進行操作。
- 在安裝之前，必須關閉水龍頭，斷開外部電源插座的電源線，斷開進口水龍頭的進水管和排水管。

安裝步驟如下：

1. 取下防鼠蓋板，取下防鼠蓋板周圍的雙面膠。

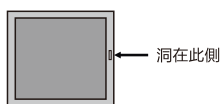

2. 將洗衣機向後傾斜，慢慢將洗衣機放到有軟墊的地面上，注意洗衣機的操作面板要向前。

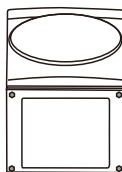

3. 將防鼠蓋板上的吸音棉朝向洗衣機內側放置，左側的定位方孔和底板周圍的螺絲孔與洗衣機底板的螺絲孔對齊。壓緊防鼠蓋板，將其固定在洗衣機的底板上。

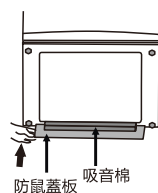

4. 用專用螺釘（大圓帽螺釘）固定防鼠蓋板左右兩側及後側，固定完畢後將洗衣機輕輕抬起，放置平穩。

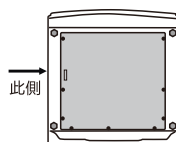

安裝

安裝排水管

警告!

- 請勿纏繞或拉長排水管。
- 正確放置排水管，以防止水溢至地板。
- 請勿將排水管的末端浸入水中。

排水管應安裝在洗衣機背面。為排出洗滌水，可用三種不同的方法安裝排水管的另一端，如下圖所示：

- 將排水管插入排水孔（1）。
- 將排水管連接到洗衣水槽（2）的分支排水管上。
- 將排水管放入水槽/盆內，使用洗衣機背面的排水管支架，並用繩子或繫帶固定（3）。為保證洗衣機使用時排水正常，排水管的高度不得高於地面100cm。

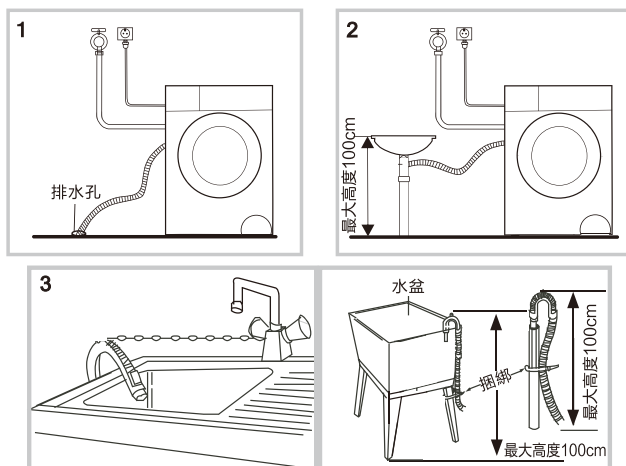

- 不使用洗衣機時，可將排水管放置在洗衣機背面，並使用軟管夾將其固定在適當位置。

警告!

- 如果排水管過長，請勿將其強行塞入洗衣機，否則將產生異常噪音。
- 因在洗滌過程中會有水排出，請勿直接平放排水軟管。
- 請確保排水管線路正確，以免排水管有扭結或從水槽中掉落。
- 請將排水管固定在洗衣機背面；請勿拆卸軟管扣。
- 洗衣機請勿超載，其最大容量為8公斤。



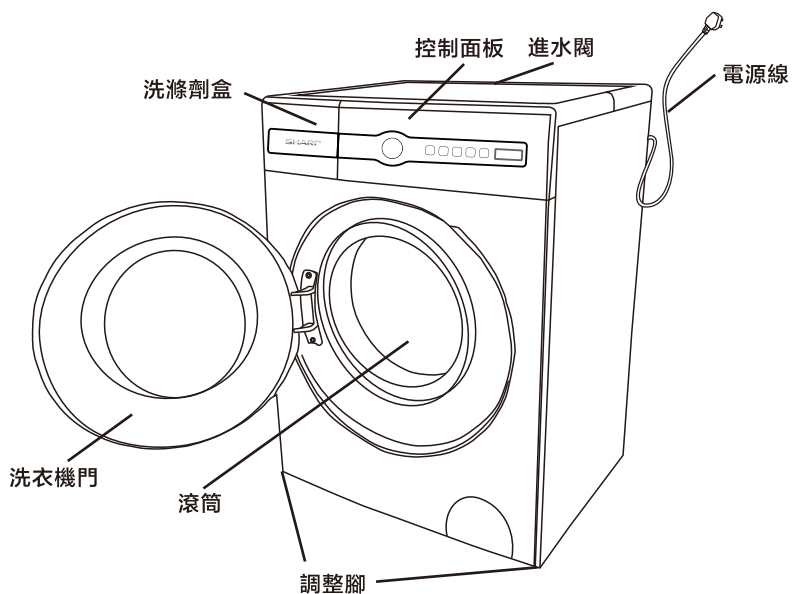

部件名稱

注意

- 建議用戶在第一次洗滌前操作滾筒清潔程式。
- 請勿忘記關閉水龍頭及拔下電源插頭，以免發生水災和火災。

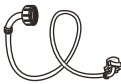

配件

使用說明書	進水管	運輸螺栓孔蓋 (4片)	扳手	防鼠蓋板螺絲 (9個)	防鼠蓋板 (1片)
					

產品規格

型號	ES-FH8BH-W
額定容量	8kg
額定電壓/頻率	220V-50Hz
水壓	0.03~1.0MPa
額定洗滌功率	85 W
額定脫水功率	350 W
額定溫水洗滌功率	1700 W
最大輸入功率	1800 W
脫水速度 (最高轉速)	1200 rpm
產品尺寸 (闊 × 高 × 深)	600 × 850 × 580mm
淨重	63 kg

機門上鎖/解鎖

機門上鎖

機器運行時，機門自動上鎖，無法打開。

機門解鎖

機器運行時，按下“啟動/暫停”按鈕，滾筒停止旋轉後，機門即可解鎖。

- 如果直接拔下電源插頭或機器運行時斷電，機門無法自動解鎖。
- 如果機器操作時打開機門，泡沫可能會溢出，請用毛巾擦淨。
- 當機器運行時，溫度較高，不可打開機門。
- 水溫過高時，不可打開機門。

洗滌劑盒

粉狀合成洗滌劑



- 使用不可溶解的洗滌劑時，如粉狀肥皂，應先溶解，再倒入注入口。

液體洗滌劑和漂白劑



- 使用低泡液體合成洗滌劑。
- 使用濃縮液體洗滌劑時，應用水稀釋兩倍，再倒入注入口。

柔順劑



- 洗滌前倒入，在最後一次過水時會自動注入。
- 使用濃縮型柔軟劑請用相同比例的水稀釋後再倒入。
- 不得超過標誌線。

液體洗滌劑



- 此隔層可倒入液體洗滌劑，以確保洗滌效能。

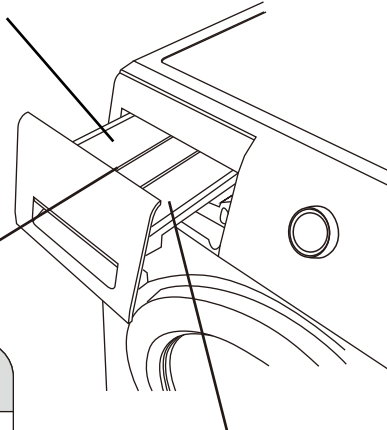

- 禁止使用高泡洗衣粉或洗滌劑。
- 按照製造商的說明使用洗滌劑。
- 洗滌劑過量會造成泡沫過多，影響過水效果，或可能造成功能故障。
- 根據衣物的種類、顏色、水溫和污漬程度選擇合適的洗滌劑。

控制面板

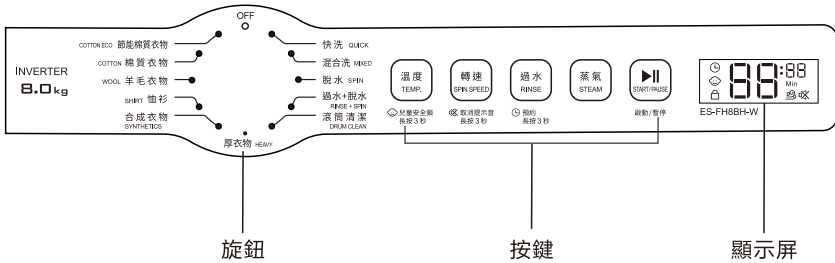

■ 程序旋鈕

旋轉程序旋鈕，即可開機。隨後可選擇所需的洗滌程式。燈亮起時將顯示所選程式。

■ 待機位置

旋轉旋鈕至待機模式 ，將機器切換到待機狀態（程式結束時自動切換到待機狀態，但旋鈕仍處於所選程式位置）。

■ 顯示屏

顯示屏展示設定、預計剩餘時間、選項和狀態。洗衣機開機時，會顯示預設設置。

: 選擇程式時，顯示屏將顯示該程式的預設時間，可根據選擇的選項更改預設時間。

: 在設定洗滌/脫水/浸洗時間和在程式運行期間時，此標誌將亮起。

: 設定兒童安全鎖功能後，此標誌將亮起。

: 此標誌亮起時，機門無法打開。

: 此標誌亮起時，蒸氣功能正在運行。

: 設定預約功能後，此標誌將亮起。

: 靜音功能啟動後，此標誌將亮起。

控制面板

■ 溫度鍵

按此鍵調較程式的預設溫度。

■ 轉速鍵

按此鍵調較程式的預設轉速。

■ 過水鍵

按此鍵調較過水次數。

■ 蒸氣鍵

按下此鍵，可在棉質、恤衫、快洗、混合洗程式中添加蒸氣功能。

■ 啟動/暫停鍵

“啟動/暫停”鍵用於啟動或暫停洗滌模式。如果需要暫時停止洗滌模式，請按“啟動/暫停”按鈕。



程序表

節能棉質衣物	溫水節能程式，洗滌時間超長
棉質衣物	通常適用於棉、亞麻布或棉混紡織物（如桌布、毛巾、內衣、恤衫等）
混合洗	適用於合成纖維和棉織物混合的溫水程式
羊毛衣物	此程式非常溫和，適用於機洗羊毛或羊毛混紡織品，以防縮水
合成衣物	此程式較為溫和，適用於合成衣物
快洗	超短程式，適用於髒污程度較輕的衣物
恤衫	適用於棉麻或混合纖維恤衫
過水+脫水	單獨的過水程式加脫水
脫水	單獨的脫水程式，速度可選擇，脫水前請排空水
滾筒清潔	適用於滾筒清潔，運行時請將所有衣物移走
厚衣物	適用於大件衣物洗滌

程序表

程式	最大負載 (kg)	預設溫度 (可選擇範圍)	預設時間	過水 (次數) (可選擇範圍)
節能棉質衣物*	8kg	60°C (cold-20-30-40-60-90°C)	1:47	2(0-6)
棉質衣物	8kg	30°C (cold-20-30-40-60-90°C)	1:07	2(0-6)
混合洗	≤6 (8kg) ≤6.5 (9kg) ≤7kg (10kg)	30°C (cold-20-30-40-60°C)	1:02	2(0-6)
羊毛衣物	≤2kg	cold (cold-20-30-40°C)	1:04	2(0-6)
合成衣物	≤6kg	30°C (cold-20-30-40°C)	1:07	2(0-6)
快洗	≤1kg	cold (cold-20-30°C)	0:15	1(0-4)
恤衫	≤3kg	30°C (cold-20-30-40-60°C)	1:05	2(0-6)
過水+脫水	8kg	—	0:20	1(0-6)
脫水	—	—	0:11	—
滾筒清潔	—	90°C	2:18	1
厚衣物	≤5kg	30°C (cold-20-30-40-60°C)	1:17	2(0-6)

*此程式用於達到能效測試標準。

程序表

程式	預設轉速 (RPM) (可選擇範圍) (8kg)
節能棉質衣物	800rpm (400-600-800-1000-1200)
棉質衣物	1000rpm (400-600-800-1000-1200)
混合洗	1000rpm (400-600-800-1000-1200)
羊毛衣物	600rpm (400-600-800)
合成衣物	800rpm (400-600-800-1000)
快洗	800rpm (400-600-800-1000)
恤衫	800rpm (400-600-800-1000)
過水+脫水	1000rpm (400-600-800-1000-1200)
脫水	1000rpm (400-600-800-1000-1200)
滾筒清潔	800rpm
厚衣物	1000rpm (400-600-800-1000-1200)

程序表

普通衣物洗滌說明

方法

1. 準備

- 放入衣物，關上機門。
- 在洗滌劑盒中放入洗滌劑或洗衣粉。
- 打開水龍頭，接入排水管，插上電源。

2. 啟動電源。

3. 選擇合適程式。

4. 選擇合適的按鍵。

5. 按“啟動/暫停”按鈕。

6. 洗滌完成後，提示音會響起。

羊毛衣物洗滌說明

方法

- 啟動電源，選擇羊毛程式。

注意

- 洗滌前請確認衣物上的洗滌標籤。

- 溫度不能超過40度，以免損壞衣物。

- 洗滌完成後，請立即取出晾曬，以免衣物變形。

- 使用羊毛洗滌劑可提高洗滌效能。

- 淺色和深色衣服分開洗滌。

其他選項和功能

預約洗滌功能

方法

●根據用戶需求，啟動電源，選擇合適的程式和按鍵。

長按“過水”鍵3秒，設定結束時間。

按“啟動/暫停”鍵啟動預約洗滌功能。(預約時間相隔為1小時，最長為24小時。)



注意

如需更改預約洗滌，請將程式旋鈕旋至待機模式^{OFF}重新設定。

預約後，將程式旋鈕旋至待機模式^{OFF}即可取消預約。

確認預約洗滌時，請按“預約”鍵。設定時間將顯示5秒。

預約洗滌時間在不同洗滌條件下是不同的。洗滌時間取決於水壓、排水管、衣物類型、水溫。

取消提示音

設定/取消方法

啟動電源，長按“轉速”鍵3秒。鬆開按鈕，“取消提示音”功能設置完成。如重複此操作，將取消該設定。



兒童保護功能

如果在程式運行前再次打開機門，機器將在操作時自動啟動兒童保護功能。首先，機門將會打開，摩打持續運轉片刻。然後，機門會解鎖至再次操作。如在等待時間內，機門被打開，機器將停止運行。



蒸氣功能

若選擇蒸氣洗滌功能在整個程式中，第一次洗滌過程後，桶內的水都將排出。然後進入蒸氣洗滌功能。加熱管加熱少量水產生蒸氣，對衣物進行薰蒸。蒸氣過程持續30分鐘。在蒸氣洗滌過程中，滾筒會不斷旋轉，以達到更好的洗滌效果。之後繼續進行過水。



兒童安全鎖

用戶可以設定兒童安全鎖功能，避免兒童在洗衣機工作時操作機器。因此，設定兒童安全鎖功能後，將無法打開機門和操作按鍵（電源鍵除外）。取消兒童安全鎖功能時，可再次打開機門。

設定/取消方法

啟動電源並長按“溫度”鍵3秒，提示音響起時，兒童安全鎖功能設置完成。如重複此操作，將取消兒童安全鎖功能。



清潔與保養

- 長時間使用後請保養機器，可以延長機器使用壽命。
- 在開始保養工作前，請務必切斷電源。

機身

- 每次洗滌後請用軟布擦拭機身。如果機身較髒，請用軟布沾取洗滌劑或肥皂水清潔機身。
- 請勿用水直接沖洗洗衣機。
- 請勿使用去污粉、稀釋劑、汽油和酒精清洗機器。

密封圈

每次洗滌後請用布擦拭密封圈。如有胸針或其他雜物，請務必取出。

清洗洗滌劑盒

請定期清洗洗滌劑盒。取出洗滌劑盒，並用清水清洗。

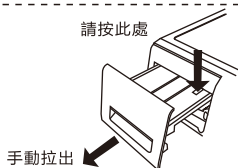

清洗進水閥（建議半年一次）

- 1.取出進水管
- 2.取出過濾網
- 3.用牙刷清潔過濾網，再重新組裝
- 4.清洗後連接進水管



滾筒清潔（建議每月一次）

長時間使用後，滾筒內可能有污垢。滾筒清潔功能可清洗內外滾筒。（注意：使用滾筒清潔功能時，請勿放入衣物和洗滌劑。）

清潔與保養

機身結冰及防凍

1. 用熱毛巾包住水龍頭和接頭。
2. 拆開進水管，放入50度的熱水中。
3. 將2-3升50度的熱水倒入滾筒中。
4. 重新組裝進水管，打開水龍頭，啟動機器。最後檢查進水管和排水管是否能正常工作。

1.



2.

拆開進水管，
放入50度的
熱水中。



3.

將2-3升50度的
熱水倒入滾筒中。

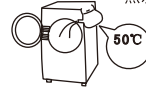

清洗排水泵過濾器（建議每月一次）

1. 按下過濾器蓋。
過濾器的蓋子可打開。
(注意：如果機器內有熱水，請讓熱水冷卻後再打開過濾器。)
2. 逆時針取出過濾器。
3. 用水清洗過濾器。
4. 順時針將過濾器組裝到排水泵中。

注意：1. 過濾器應組裝緊密，以免漏水。
2. 請勿在機器工作時清洗過濾器。

排水泵過濾器

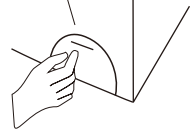

問題和解決方案

條件	原因
無法打開機門	<ul style="list-style-type: none">● 水溫過高或停電● 已設定兒童安全鎖功能● 衣服夾在機門和密封圈之間
異味	<ul style="list-style-type: none">● 因洗衣機使用部分橡膠物料，所以剛開始使用機器時會有橡膠味
洗滌和過水用水減少	<ul style="list-style-type: none">● 滾筒洗衣機耗水量更少
無進水	<ul style="list-style-type: none">● 水龍頭是否打開● 水管是否凍結● 排水泵過濾器是否堵塞
中途進水	<ul style="list-style-type: none">● 如水位下降，系統會自動加水
機器洗滌過程中排水	<ul style="list-style-type: none">● 泡沫洗滌劑過多
剩餘洗滌時間變化	<ul style="list-style-type: none">● 如果衣物分佈不均，洗衣機將自動加水，以保持平衡● 剩餘時間按15L/min進水量計算。所以剩餘時間會因水壓不同而延長或縮短● 如果衣物分佈不均，洗衣機會延長脫水時間
脫水時有異常聲響	<ul style="list-style-type: none">● 插頭是否正確插在插座內● 運輸螺栓是否移除● 滾筒內是否有髮夾、硬幣或其他異物
斷電後機器無法工作	<ul style="list-style-type: none">● 切斷電源後，洗衣機無法運轉。如果恢復電源後，機器仍無法運轉，請按“啟動/暫停”鍵重新設定程式
緊急開門	<ul style="list-style-type: none">● 當斷電時間較長而又想取出衣物時，拔下電源線，等待滾筒停止轉動，拉下洗衣機底部右下角的應急繩。若聽到輕微響聲即可開門（請先確認滾筒內水位及水溫為60°C以下）

錯誤訊息說明

故障程式碼	現象	檢查要點	解決方法
無法顯示	停止運行	<ul style="list-style-type: none"> ● 插座是否通電 ● 插座是否通電或斷電 ● 漏電保護器開關是否斷開 ● 是否設定預約功能 	
E11	不進水	<ul style="list-style-type: none"> ● 水龍頭是否打開 ● 檢查水管是否結冰 ● 排水泵過濾器是否堵塞 ● 自來水是否有供應 	檢查處理後，按“啟動/暫停”鍵
E12	不排水	<ul style="list-style-type: none"> ● 排水管是否正確放置 ● 排水高度是否過高 ● 檢查排水管是否堵塞 ● 排水管長度是否合適 	檢查處理後，按“啟動/暫停”鍵
H	無法打開機門	<ul style="list-style-type: none"> ● 確保不要用熱水 ● 洗滌時水溫是否過高 ● 乾衣中止 	待水溫降至安全範圍時，機門自動打開
U3	不脫水	<ul style="list-style-type: none"> ● 機器是否平穩放置 ● 衣物數量是否過多或放入大件衣物 ● 衣物是否太少 ● 毛毯是否卷成團狀放入 	建議重新分配衣物，加2~3件衣物，檢查確認後，關上機門，按啟動/暫停鍵
U4	機門未關		關閉機門，待“門鎖提示燈”亮起後，按“啟動/暫停”鍵，重新啟動本機
其他	鳴聲		按“啟動/暫停”鍵，重新啟動本機，如仍未能解決問題，請聯系服務中心

SHARP

SHARP CORPORATION

SHARP

Front Load Washing Machine

ES-FH8BH-W

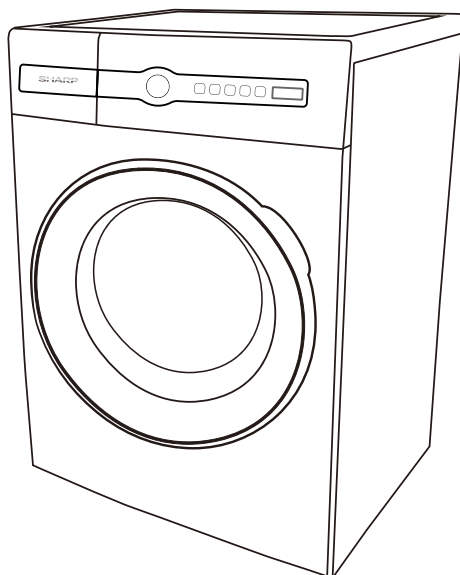

Operation manual

Thank you for purchasing our product.

Please read this operation manual and safety precautions carefully before use.

Please keep this manual in a safe place.

Our product is specially designed for household use only.

CONTENTS

INSTRUCTION BEFORE WASHING

SAFETY PRECAUTIONS	EN-2
INSTALLATION	EN-4
NAME OF PARTS.....	EN-10
ACCESSORIES.....	EN-10

OPERATION

SPECIFICATIONS	EN-11
DOOR LOCK AND UNLOCK.....	EN-12
INTRODUCTION OF DETERGENT DISPENSER.....	EN-13
INTRODUCTION OF CONTROL PANEL	EN-14
PROGRAM INTRODUCTION	EN-16
EXTRA OPTIONS AND FUNCTIONS	EN-20

CLEAN AND MAINTENANCE

CLEAN AND MAINTENANCE	EN-21
PROBLEMS AND SOLUTIONS	EN-23
TROUBLESHOOTING	EN-24



SAFETY PRECAUTIONS

- To protect the user and other people's health and property, be sure to observe the following safety notice.









WARNINGS

Please read this part carefully for proper operation before using your machine.



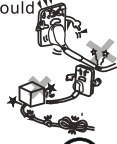









- The precautions stated here are classified as "Warning" and "Attention" according to the damage and the emergency caused by misoperation, and are described respectively in line with the marks below.

 Warning	This indicates that the failure to follow the instructions can cause serious injury or death.
 Attention	This indicates that the failure to follow the instructions can cause the minor injury or damage to the product..

		
This mark indicates the content of warning or attention.	This mark indicates the prohibited action.	This mark indicates the compulsory action to be carried out.

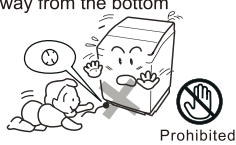
 Warning	
<ul style="list-style-type: none">  Dismantling, repair or alterations should only be carried out by professional technician as otherwise you may be subject to electric shock, may cause fire or get injured. 	<ul style="list-style-type: none"> This washing machine is equipped with the electricity wire with bielectrode grounding socket. The creepage protector shall be used if possible.
<ul style="list-style-type: none"> Electricity supply must be unplugged with dry hands. Otherwise, this may cause electric shock. 	<p>To prevent electricity leak which may cause injuries.</p> 
<ul style="list-style-type: none"> Damaged or loosen wire or plug should not be used. Otherwise electric shock, short circuit or fire may take place. Do not damage wire. Do not damage or alter the wire forcibly bend, pull twist or handle the wire. Beside, please do not put weigh on or trap the wire. 	<ul style="list-style-type: none"> Please use the single socket with special voltage and current matched with plug marked specification. The share of the same socket with other electric appliances may cause fire due to excessive.
<ul style="list-style-type: none"> Do not put water in direct contact with the unit during maintenance and repair. This may cause short circuit or electric shock. 	<ul style="list-style-type: none"> Thoroughly wipe the power plug when dirt is adhering the prong or around the base of the prong. Failure to do so may cause a fire.
<ul style="list-style-type: none"> Do not put gasoline, benzine, alcohol, thinner of fabrics with these stains into or near to the washing machine. To prevent fire or explosion which may cause injuries. 	<ul style="list-style-type: none"> Washing machine should not be installed in humid place or in places exposed to wind and rain. Otherwise, electricity leak causing electric shock or fire may occur. 
	<ul style="list-style-type: none"> This washing machine is strictly prohibited to get close to the locations with candle, mosquito-repellent incense, dog-end or other kinds of open flame. To avoid injuries caused by the lock damage. Do not operate the machine when there is gas leak. 

⚠ WARNINGS

<ul style="list-style-type: none"> ● Keep child away from the washing spinning basket and do not place box or shelves next to the washing machine. Children may fall into the basket resulting in injuries. This appliance is not intended for use by persons (including children) with reduced physical, sensory or mental capabilities, or lack of experience and knowledge, unless they have been given supervision or instruction concerning use of the appliance by a person responsible for their safety. 	<ul style="list-style-type: none"> ● The glass door becomes hot in process of high-temperature washing . Do not touch the door when the machine is on, especially children. ● If you need to open the door during high-temperature washing program, wait until the temperature drop to safe standard, and the door unlocked automatically. ● Packing material may be dangerous to kids, please keep all packing material (plastic bag foam etc) far away from the kids. 
<h2 style="margin: 0;">⚠ Attention</h2>	
<ul style="list-style-type: none"> ● Do not pull the wire from the socket when unplugging the unit. To avoid electric shock or fire caused by short circuit . 	<ul style="list-style-type: none"> ● Please unplug the unit when not using the unit for a long period of time. Electric shock or leakage may occur due to deformation of plastic parts of the unit. 
<ul style="list-style-type: none"> ● Electricity supply must be unplugged with dry hands during maintenance and repair. Otherwise, electric leakage causing injuries may occur. ● If the power cord or supply cord is damaged, the manufacturer or its service agent or similarly qualified person must replace it in order to avoid a hazard. 	<ul style="list-style-type: none"> ● Water of above 50°C should not be used for washing . Electric shock or leakage may occur due to deformation of plastic parts of the unit. 
<ul style="list-style-type: none"> ● Do not wash, rinse and spin the water proof fabric or cloth. Sleeping bag, raincoat, cover of skiing, utilities, bicycles, cars and motors. Otherwise may lead to injury by abnormal vibration during spinning or damage the washing machine, wall, floor and clothes. 	<ul style="list-style-type: none"> ● Do not stand on or put weight on the top of the unit. Otherwise, deformation and damage may occur and causing injuries. ● Two people are required in moving or transportation. 
<ul style="list-style-type: none"> ● Keep hands and feet away from the bottom of washing machine when it is working. Parts in working under the product may cause injuries. 	<ul style="list-style-type: none"> ● Check water supply hose connection by turning on the water before washing. To prevent damages caused by possible water leakage due to loosen screw or not tightly. ● The new hose-sets supplied with the appliance are to be used and that old hose-sets should not be reused. ● Do not block the ventilation openings on the bottom of washer by carpeting when the washer is installed on a carpeted floor. 
<ul style="list-style-type: none"> ● Water supply hose should be tightly screwed to the unit. Failure to do so may result in water leakage. Used for a long period of time, the unit may result in water leakage caused by loosen union nut. So please check it in time and screw tightly again. 	<ul style="list-style-type: none"> ● Please turn off the water tap when not using the unit. To prevent damages caused by water leakage. 

INSTALLATION

Unpacking the washing machine

CAUTION: EXTREMELY HEAVY!

- A team lift or mechanical aid is required when moving this appliance.
- Keep the washing machine as upright as possible during transportation.
- This product has been packaged to protect it against transportation damage. Remove all packaging materials from inside the drum and around the appliance.
- Keep the original packaging carton and materials in a safe place. It will help prevent any damage if the product needs to be transported in the future, and you can use it to store the appliance when it is not in use. In the event that the carton is to be disposed of, please recycle all packaging materials where possible.
- Plastic wrapping can be a suffocation hazard for babies and young children, so ensure all packaging materials are out of their reach and disposed of safely.
- Carefully lift the washing machine and remove the base packing. Make sure the base protection device is removed together with the bottom piece. If not, lay the unit down on its side, then remove the small foam piece from the base of the unit manually.
- Remove any tapes securing the cord and drain hose.
- Remove all accessory parts from the drum.

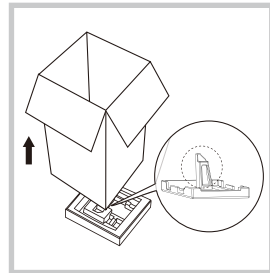

Checking the package contents

- Check all parts of the package and ensure you have received all items.
- Check the washing machine for any damage from transportation. Unwind the power cord to its full length and inspect it for damage. **Do not use the appliance if the appliance or its cord has been damaged or is not working properly.** In case of damage, or if anything is missing, contact our after sales support centre for advice on examination, repair or return of the damaged product.
- Read this manual to familiarise yourself with all the parts and operating principles of the wash. Pay particular attention to the safety instructions on the previous pages.

WORKING CONDITION

- Do not operate the washing machine in temperatures outside its normal working condition (0–40°C). Using it in temperatures below 0°C may damage the machine's inlet valve and draining systems.
- If the machine is stored in an area where the temperature drops to below 0°C, transfer it to an area with a warmer ambient temperature before use and ensure no residual water is frozen in hoses and pipes.
- Domestic use only: The appliance is designed for private household use only. It is not suitable for commercial, industrial or trade use.

INSTALLATION

Selecting the location

Before installing the appliance, make sure the location meets the following requirements:

- The surface is rigid, dry and level – if it is not level, please adjust the levelling legs (see page 6).
- The position is protected from direct sunlight, water and weather.
- There is sufficient ventilation.
- There is 100mm space between any walls and the furthest protruding part of the machine.
- The room temperature is above 0°C.
- The position is at least 200mm from heat sources.
- Ensure that the appliance shall be installed so that there is a distance of at least 200 mm between the appliance enclosure and external heat sources, such as appliances containing heating elements.
- The machine will not stand on the power cord.
- The area is not carpeted (if this cannot be avoided, place a plastic mat underneath the machine and make sure any ventilation openings in the base are not obstructed).
- Installation surface: This washing machine must be installed on a flat, even and stable ground to avoid overturning during use or maintenance. Do not place it on carpet. If the machine must be positioned on carpet, place a plastic mat underneath the machine and make sure any ventilation openings in the base are not obstructed.

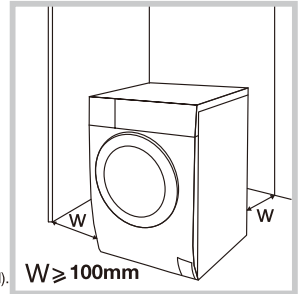

Do **NOT** install the appliance:

- Behind a lockable or sliding door, or a door with a hinge on the opposite side of the machine, in such a way that a full opening of the appliance door is restricted.
- In a tight-fitting cabinet.

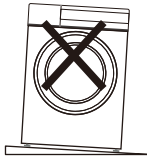

1. On the sloping ground

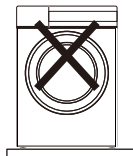

2. On the platform and the bracket

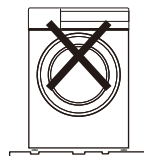

3. On the concavo - convex ground

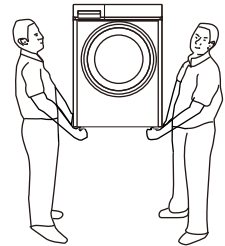

Transportation

Two people are needed to carry the machine.
One person on one side carries the machine by holding the machine feet.

INSTALLATION

Remove the bolt used to fix the machine in transportation

To protect the machine in transportation, there are 4 bolts inserted into the inner part of the machine. Remove these bolts before use. (Otherwise there will be strong shock, noise, and disfunction in spin process.)

1. Unscrew the bolts that are fixed before transportation by spanner(4 bolts)
2. Remove the bolts horizontally.
3. Fit the lid into the holes .

- Let the sales force or professional maintenance worker to install the machine.
- Keep the dismantled bolts carefully , you will need them in house moving.
- As the picture shows, please be sure to confirm that the base protection device is not stuck at the bottom of the washing machine before use, otherwise it will affect the normal use of washing machine.

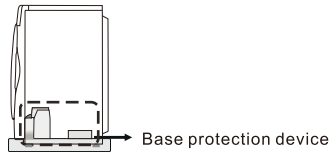
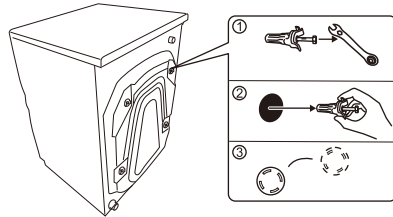

Adjust the machine horizontally

There will be strong shock, noise, and disfunction in operation if the washing machine is not steadily installed. Please adjust the front adjustable leg .

Methods are as follows:

1. Check whether the washer is on a level surface using a plumb line as shown in below figure.
 - The washer is on level ground floor if the Frame line of washer is parallel with the plumb line.
2. Adjust the Adjustable Leg of washer if necessary to make the washer level as shown in below figure.
3. Put your hands on the washer diagonally, press and shake the washer slightly to make sure that the washer is steady.

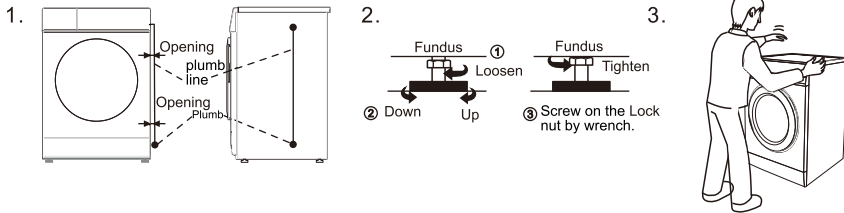

INSTALLATION

Connecting the Supply Hose

1. Check that sealing washers are firmly seated.
2. Attach the curved end of the hose to the inlet valve of the washing machine, Tighten the coupling nuts securely by hand.
3. Attach straight end of the hose to the tap. Tighten the coupling nuts securely by hand.
4. Turn on the taps and check for leaks. Tighten the coupling nuts firmly if there is any leakage. If water pressure is strong, close the water tap completely then open it slightly.

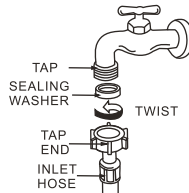

CAUTIONS:

- Do not use water which is hotter than 50°C.
- Do not connect to the hot water supply.
- If your faucet is not suitable, please consult your dealer.

Installing Water Supply Hose to the Washer

Turn the nut clockwise till the nut turned tight while holding the hose.

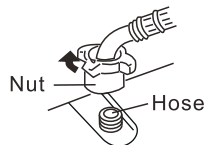

Turn the nut counterclockwise after turning the faucet off when you want to detach the water supply hose.

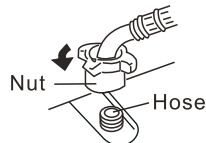

INSTALLATION

Rat cover installation

ATTENTION:

- Please install before removing the transport fixing bolts, installation requires at least two people to carry out the operation.
- Before installing the rat cover, the tap must be turned off and the power cable disconnected from the external power outlet, the inlet pipe from the inlet tap and the drain pipe from the drain outlet.

The installation steps are as follows:

1. Remove the rat cover and remove the double-sided adhesive stickers from around the rat cover.

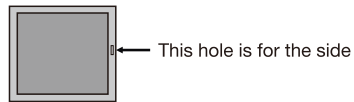

2. Tilt the washing machine backwards, Slowly lower the washing machine onto a cushioned surface, taking care that the operating panel of the washing machine is facing forward.

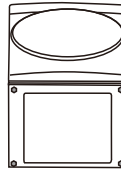

3. Place the sound-absorbing foam on the rat cover towards the inside of the washing machine, with the positioning square holes on the left and the screw holes around the backing plate aligned with the screw holes in the base plate of the washing machine. Press around the rat cover to attach it to the base plate of the washing machine.

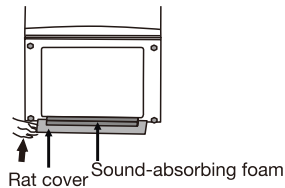

4. Fix the left and right sides of the rat cover and the rear side with special screws (large round cap screws), after the fixing is completed lift the washing machine gently and place it smoothly.

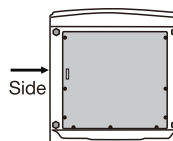

INSTALLATION

Installing the drain hose

WARNING!

- Do not kink or protract the drain hose.
- Position the drain hose properly in order to prevent water spillage onto the floor and potential damage.
- Never immerse the end of the drain hose in water.

The drain hose is installed at the back of the machine. For drainage of the washing water, you can install the other end of the hose three different ways, as illustrated:

- Lead the drain hose into a drain spout (1).
- Affix the drain hose into a branch drain pipe of the laundry sink (2).
- Lead the drain hose into a sink/basin, using the drain hose support at the back of the machine, and secure it with a rope or tie (3). To ensure proper drainage when the washing machine is in use, the height of the drain hose must not be higher than 100cm above ground.

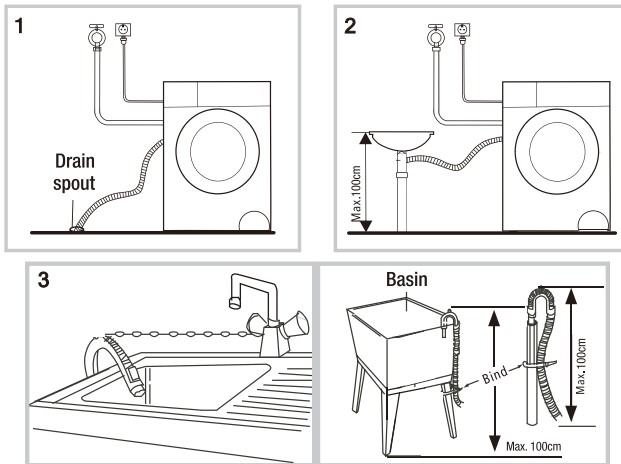

- When the washing machine is not in use, you may leave the drain hose at the back of the machine, using the hose clips to keep it in place.

WARNING!

- If the drain hose is too long, do not force it into the washing machine as it will cause abnormal noise.
- Never lay down the drain hose as water will be discharged.
- Be sure the drain hose is properly routed so it will not kink or lift off the sink.
- Leave the drain hose affixed to the back of the machine; do not remove the hose buckles.
- Do not overload the washer; its maximum capacity is 8kg.

NAME OF PARTS

ATTENTION

- We suggest the user to run the tub clean program before the 1st time washing.
- Don't forget to close the water tap and take down the power plug to avoid any flood and fire disaster.

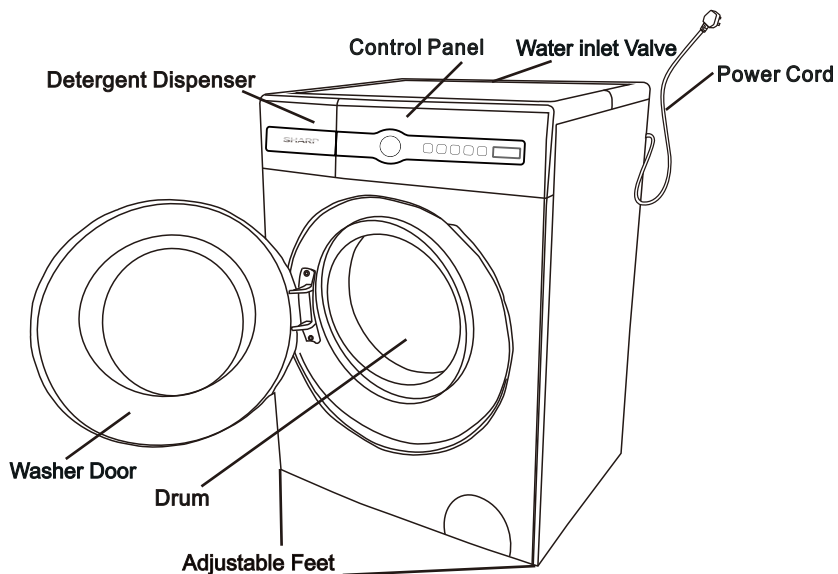

ACCESSORIES

Operation manual	Water Supply Hose	Lid (4Pieces)	Spanner	The Screw of Rat Cover (9Pieces)	Rat Cover (1Piece)

SPECIFICATIONS

Model	ES-FH8BH-W
Rated capacity	8kg
Rated voltage/frequency	220V-50Hz
Water Pressure	0.03~1.0MPa
Rated washing power	85 W
Rated spin speed	350 W
Rated warm washing power	1700 W
Maximum input power	1800 W
Spin speed(Maximum)	1200 rpm
Product dimensions(W × H × D)	600×850×580mm
Net weight	63 kg

DOOR LOCK AND UNLOCK

DOOR LOCK

When the machine is working, the door locks automatically. It can't be opened.

DOOR UNLOCK

When the machine is working, the user press the “START/PAUSE” button, the door can be unlocked after inner tub stopping spin.

- If take down the power plug directly or power cut when the machine is running, the door can't be unlocked automatically.
- If open the door when the machine is working, the froth may exceed and please clean it with towel.
- The user can't open the door when the machine is running with a high working temperature.
- The user can't open the door when the water temperature is high.

INTRODUCTION OF DETERGENT DISPENSER

Powder synthetic detergents



- For the undissolved detergents, for example: powder state soap, dissolve it in advance, then pour into the case.

Liquid detergent and bleach



- Use low bubble liquid synthetic detergents.
- For the concentrated liquid detergents, diluted it double times with water, then pour into the case.

Softener



- Put into the same before washing, it will be poured into tub automatically at the last round of rinse.
- For the concentrated detergents, use corresponding proportion of water to dilute it, then pour it into the case.
- No exceed to the full mark line.

Liquid detergents



- Liquid detergents can be poured in this case to ensure the wash performance.

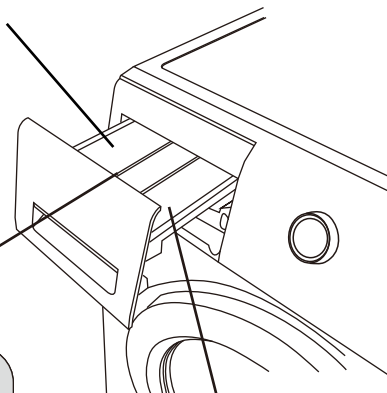

- High bubble washer powder or detergents is forbidden.
- Use the detergents in accordance with the instruction by its manufacturer.
- Excessive detergents will cause too much bubble and affect the rinse, also create function faults.
- Choose suitable detergents in accordance with the type and color of clothes, the water temperature and the stain.

INTRODUCTION OF CONTROL PANEL

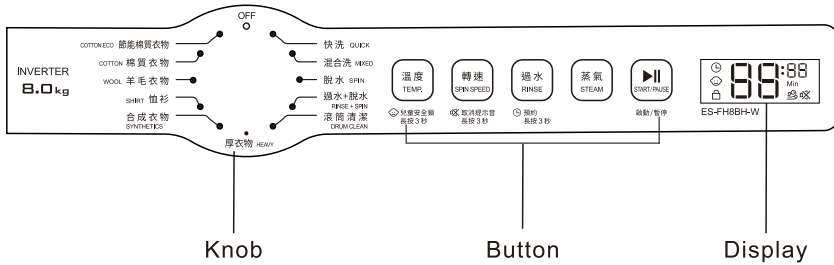

■ Program Knob

Turn the program knob to switch on the machine and select your desired wash program. The light will light up to indicate the selected program.

■ Stand-by Mode

Turn the knob to the stand-by mode **OFF** to switch the machine to stand-by (it switches to stand-by automatically at the end of the program, but the dial remains on the selected program position).

■ Display

The display shows the settings, estimated remaining time, options, and status messages. When the appliance is turned on, the default settings in the display will illuminate.

88:88: When a program is selected, the default time for that program is displayed. The default time can be changed according to the selected option.

MIN: When set the wash/spin/soak time, and during program running, this icon is illuminated.

: After set child lock function, this icon is illuminated.

: When this icon is illuminated, the door cannot be opened.

: When the icon is illuminated, the Steam function is under running.

: After set Delay function, this icon is illuminated.

: After set mute function, this icon is illuminated.

INTRODUCTION OF CONTROL PANEL

■ TEMP. button

Press to adjust a program's default temperature .

■ SPIN SPEED button

Press to adjust a program's default spin speed .

■ RINSE button

Press to adjust the rinse times.

■ STEAM button

Press this button, to add the Steam function in the COTTON, SHIRT, QUICK WASH, MIXED program.

■ START/PAUSE button



This “**START/PAUSE**” button is used to start or pause the wash cycle.

If a temporary stop of the wash cycle is needed, press the “**START/PAUSE**” button.

PROGRAM INTRODUCTION

COTTON ECO	A warm water eco program with an extra long washing time used for energy efficiency testing
COTTON	Normally soiled cottons, linens or cotton mix fabrics (e.g. table linen, towelling, underwear, T-shirts etc.)
MIXED	A warm water program for a mixed load of synthetic and cotton textiles
WOOL	A specially gentle program for machine-washable wool or wool-blend textiles. Designed to prevent shrinkage
SYNTHETICS	A gentle program for synthetic or synthetic blend textiles
QUICK	An extra short program for a few lightly soiled items
SHIRT	Cotton or mixed fibre shirts and blouses
RINSE+SPIN	Separate rinse program with spin
SPIN	Separate spin program with selectable speed. Drains water before spinning.
DRUM CLEAN	A drum cleaning program designed for use without laundry items
HEAVY	This program is specially designed for washing HEAVY

PROGRAM INTRODUCTION

Program	Max. Load (kg)	Default Temperature (Selectable temp.range) (°C)	Default Time (hr:min)	Rinse(Times) (Selectable rinse times)
COTTON ECO*	Rated capacity 8kg	60°C (cold-20-30-40-60-90°C)	1:47	2(0-6)
COTTON	Rated capacity 8kg	30°C (cold-20-30-40-60-90°C)	1:07	2(0-6)
MIXED	≤6 (8kg) ≤6.5 (9kg) ≤7kg (10kg)	30°C (cold-20-30-40-60°C)	1:02	2(0-6)
WOOL	≤2kg	cold (cold-20-30-40°C)	1:04	2(0-6)
SYNTHETICS	≤6kg	30°C (cold-20-30-40°C)	1:07	2(0-6)
QUICK	≤1kg	cold (cold-20-30°C)	0:15	1(0-4)
SHIRT	≤3kg	30°C (cold-20-30-40-60°C)	1:05	2(0-6)
RINSE+SPIN	Rated capacity 8kg	–	0:20	1(0-6)
SPIN	–	–	0:11	–
DRUM CLEAN	–	90°C	2:18	1
HEAVY	≤5kg	30°C (cold-20-30-40-60°C)	1:17	2(0-6)

*This program was used for energy efficiency testing to the standard.

PROGRAM INTRODUCTION

Program	Default Spin Speed(RPM) (Selectable spin speed)(8kg)
COTTON ECO	800rpm (400-600-800-1000-1200)
COTTON	1000rpm (400-600-800-1000-1200)
MIXED	1000rpm (400-600-800-1000-1200)
WOOL	600rpm (400-600-800)
SYNTHETICS	800rpm (400-600-800-1000)
QUICK	800rpm (400-600-800-1000)
SHIRT	800rpm (400-600-800-1000)
RINSE+SPIN	1000rpm (400-600-800-1000-1200)
SPIN	1000rpm (400-600-800-1000-1200)
DRUM CLEAN	800rpm
HEAVY	1000rpm (400-600-800-1000-1200)

PROGRAM INTRODUCTION

User instruction for the normal clothes

Method

1. Preparation
 - Put the clothes in and close the door.
 - Put the detergent or washing powder into the detergent box.
 - Switch on the water tap, put the drain-pipe, plug the power supply.
2. Turn on the power.
3. Choose the suitable program.
4. Choose the suitable button.
5. Press the “START/PAUSE” button.
6. When finishing washing, the buzzer will sound.

Instruction to wool program

Method

- Turn on the power and choose the wool program.

Attention

- Please confirm the washing mark on the clothes before washing.
- When finishing wash, please take the clothes out immediately for airing in order to avoid clothes deformation.
- The temperature can't be setting more than 40 degree to avoid clothes damage.
- Using the wool detergent can improve the washing performance.
- Wash light colour clothes and dark colour clothes separately.

EXTRA OPTIONS AND FUNCTIONS

Introduction of Delay Wash

Method

- Turn on the power and choose the suitable program and buttons according to user's requirement.

Press the RINSE button for 3 seconds to set the finishing time.

Press the START/PAUSE button to start-up the delay wash function.
(Delay time has every one hour interval and maximum is 24hours.)



Attention

If need to change the delay wash, please turn the program knob to the stand-by mode ^{OFF} and set again.

After reservation, user can cancel it if turn the program knob to the stand-by mode ^{OFF}.

When confirm the delay wash, please press the delay button. The setting time will display for 5 seconds.

Delay wash time is different in different conditions. It depends on water pressure, drain, clothes type, water temperature.

Cancel the Buzzer

Set/Cancel method

Turn on the power and press "SPIN SPEED" button for 3 seconds. When release the button, "Cancel the buzzer" function is finished setting. If repeat this action, the setting will be cancelled.



Child Protection Function

If the door is opened again before program running, the machine will start the child protection function automatically when working.

Firstly, the door will be opened and motor will be running for a while. And then, the door will be unlocked for a while till working again. If during the waiting time, the door is opened, the machine will be stopped.



Steam Function

If the steam wash function is chosen in the whole program, after 1st cycle wash process, all the water drain out. Then entering the Steam Wash function.

The heating tube heats a small amount of water to produce steam, which fumigates the clothing. All the steam process will last 30mins. In the Steam Wash function process, the drum will continue rotate, to achieve better effective.

After that, will continue the Rinse process.



Child Lock Function

User can set child lock function in order to avoid child operating the machine when it is working. So the door can't be opened and the buttons (except power button) can't be handled. When cancel this function, door can be opened again.

Set/Cancel method

Turn on the power and press "TEMP." button for 3 seconds till the buzzer sound. The child lock function is finished to set.

If repeat this action, the child lock function will be cancelled.



CLEAN AND MAINTENANCE

- Please maintain the machine after long time using. It can extend the service life.
- Please take off the power supply when maintenance.

MACHINE BODY

- Please use soft cloth to clean the body after washing every time. If there is much dirty, please put some detergent or soap water on the cloth to clean the body.
- Please don't use water to flush the machine directly.
- Dirty powder, diluent, petrol and alcohol are forbidden to use to wash the machine.

DOOR GASKET

Please use cloth to clean the gasket after washing every time. If there are brooch or other sundries, please make sure to take them out.

DETERGENT BOX CLEAN

Please clean the detergent box regularly. Take out the box and clean it with water.

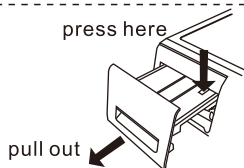

WATER INLET VALVE CLEAN (ONE TIME PER HALF OF YEAR SUGGESTION)

- 1.Take out the inlet pipe
- 2.Take out the filter screen
- 3.Use the toothbrush to clean the filter scree and then assemble it again
- 4.Connect the inlet pipe after cleaning.



DRUMCLEAN (ONE TIME MONTHLY SUGGESTION)

There may be dirty rest in the drum after long time using. The drum clean function can clean the inner and external drum. (Attention: please don't put in clothes and detergent when using drum clean function.)

CLEAN AND MAINTENANCE

Machine frozen

1. Using hot towel to envelop the water tap and connector.
 2. Disassemble the inlet pipe and put it into 50 degree hot water.
 3. Put 2-3liter 50 degree hot water into tub.
 4. Assemble the inlet pipe again, open the water tap and start the machine.
- At last, please examine whether the inlet pipe and drain pipe can work normally.

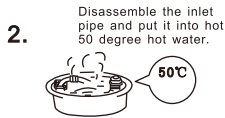
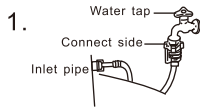

CLEAN FILTER OF PUMP (ONE TIME MONTHLY SUGGESTION)

1. Press the groove of pump.
The cover of filter can be opened.
(Attention: If there is hot water in the machine, please wait for cooling and then open the filter.)
2. Take out the filter anticlockwise.
3. Wash the filter with water.
4. Assemble the filter into the pump clockwise.

Attention: 1. The filter should be assembled tightly in order to avoid water leakage.
2. Please don't clean the filter when the machine is working.

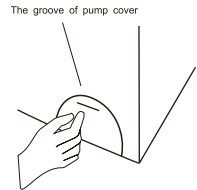

PROBLEMS AND SOLUTIONS

Condition	Reason
Door can't be opened	<ul style="list-style-type: none"> ● Water temperature is too high or power cut. ● Setting child lock function. ● The clothes is clamped between door and gasket.
Peculiar smell	<ul style="list-style-type: none"> ● Because using rubber components, it has rubber smell at the beginning.
Less water for washing and rinsing wash	<ul style="list-style-type: none"> ● Front load washer consumes less water
No water	<ul style="list-style-type: none"> ● If the tap is turning on or not ● If the water pipe is frozen or not ● If the filter is blockage or not
Halfway inflow the water	<ul style="list-style-type: none"> ● If the water level drop, the system will automatically filling water
Drainage when the machine is washing	<ul style="list-style-type: none"> ● too much bubbly detergent
Residual time change	<ul style="list-style-type: none"> ● washing machine will automatically filling water to keep balance, if the clothes are misdistributed . ● The rest time is calculated based on 15L/min inflow. So according to different water pressure, time will be extended or shorten. ● washing machine will extend spinning time, if the clothes appear tilt.
During spinning abnormal sound	<ul style="list-style-type: none"> ● Is the plug properly inserted into the socket? ● Is the carriage bolts have been removed? ● Is there a hairpin, coins or other foreign objects fall into drum?
Failure to work after power failure	<ul style="list-style-type: none"> ● When power cut off, the machine will not revolve. If recover the power, machine still not revolve, please press "power turn on/off" then reset program.
Emergency open door	<ul style="list-style-type: none"> ● When the power failure for a long time and you want to take out the clothes, unplug the power cord, waiting for the inner drum stop, pull down the emergency rope on the bottom right corner of machine, listening a slight noise then you can open the door. (Confirm the water level below the drum and water temperature below 60℃ inadvance.)

TROUBLESHOOTING

Fault code	Phenomenon	Inspection point	Solution
No display	Out of operation	<ul style="list-style-type: none"> ● Whether the outlet have electricity ● Whether the outlet is plugged in power cut or not ● Leakage protector switch off or not ● Set up delay function or not 	
E11	No water	<ul style="list-style-type: none"> ● Tap turn on/off ● Ensure the water pipe has been frozen or not ● Ensure the filter has been blockage or not ● Water stopped or not 	Press the “START/PAUSE” button
E12	Undrained	<ul style="list-style-type: none"> ● Ensure the drain pipe in the right place ● Drain height too high or not ● Ensure the drain-pipe has been blockage or not ● Ensure the drain-pipe length 	Press the “START/PAUSE” button
H	Door can't be opened	<ul style="list-style-type: none"> ● Make sure don't use hot water ● The water temperature is high when washing ● Suspension of drying 	Automatic unlocking Until the temperature drops to safety level
U3	No dehydration	<ul style="list-style-type: none"> ● Ensure the washer in the right place and steady ● Make sure don't have too much clothes and too big clothes Button,when there have fewer clothes. ● Fewer dehydrated clothes ● Don't rolled up the blanket into the machine. 	Add 2 pieces of cloth and Press the “START/PAUSE” button
U4	Door not closed		Close the door, until the “locked” light on, confirm it then press “ START/PAUSE ” button to reoperation
Other code	Alarm		Press “START/PAUSE” button to reoperation, If still can't solve the problem, please contact the service center

SHARP

SHARP CORPORATION