

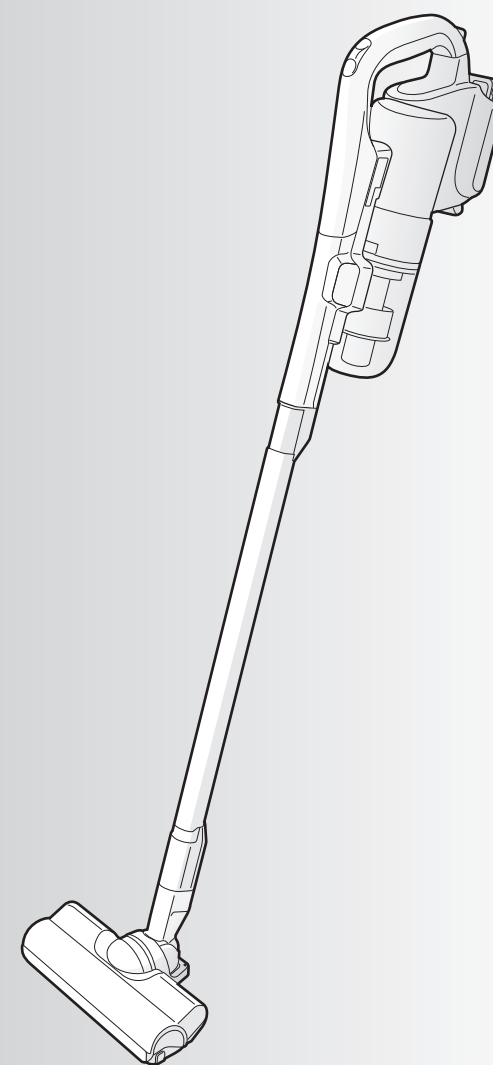

SHARP®

Model / 型號

EC-A1RHK



Cordless Vacuum Cleaner

Household use

Operation Manual

CONTENTS

Pages

SAFETY PRECAUTIONS	EN-1
PART NAMES	EN-5
PREPARATION	EN-7
VACUUMING	EN-9
EMPTYING THE DUST CUP	EN-13
MAINTENANCE	EN-15
STORAGE	EN-19
SPECIFICATIONS	EN-20
TROUBLESHOOTING	EN-21

ENGLISH

充電式吸塵機 家庭用

使用說明書

目錄

頁數

安全注意事項	CN-1
各部份名稱	CN-5
準備	CN-7
操作方法	CN-9
清理垃圾	CN-13
保養	CN-15
收納	CN-19
規格	CN-20
故障時的檢查事項	CN-21

中文

SHARP

製造廠商：SHARP CORPORATION
(中國生產) MADE IN CHINA



Printed in China
TINSQA001VBRZ 18L-①

非常感謝您購買本產品。
請詳細閱讀此說明書後，再正確使用。
在使用前，請務必閱讀「安全注意事項」。
請務必把此說明書與保固書放在隨時看得到的地方。

SAFETY PRECAUTIONS 2

Information on Battery



Danger

Preventing accidents and major injuries from electrocution or fire disaster and the like.



- Do not use the battery with any appliances other than the vacuum cleaners manufactured by Sharp and do not disassemble, modify or separately charge the battery. (Risk of fire disaster, electrocution or injury.)
- Do not allow any metal object, such as a needle or a pin to contact a terminal and do not transport or store the product with such articles as necklaces or hair pins.
- Do not pierce the product with a nail, hit with a hammer, step on the product or otherwise give strong impact or throw the product.
- Do not use any battery that has been deformed or scratched from dropping and the like.
- Do not throw the product into fire or heat it.
- Do not place the product near fire or space heater, a location exposed to direct sun light or at a location with high temperature such as inside a car parked under the flaming sun and the like.
- Do not immerse or wet the product with water.
- Do not use any charger for a battery that is not specified by Sharp. (Risk of heating, smoke generation, bursting, ignition of fire or liquid leakage.)



- Always use a battery that is specified by Sharp. (Risk of heating, smoke generation, bursting or ignition of fire.)
- When the liquid from inside the battery leaks and comes in contact with the eye, do not rub and immediately rinse out the liquid from the eye using clean water such as tap water and receive treatment by a physician right away. (Risk of harm to the eyes.)



Warning

Matters for preventing electrocution, fire disaster, electricity leaks and major injuries



- Do not use the battery when there is emission of smell, heat, liquid leakage, discoloration, deformation and any other abnormality that was not present previously. (Risk of heating, smoke generation, bursting or ignition of fire.)
- Do not touch the battery with a wet hand. (Risk of heating, ignition of fire or electrocution.)



- When the liquid from inside the battery leaks and comes in contact with the skin or clothing, immediately rinse out the liquid from the eye using clean water such as tap water. (Risk of harm to the skin.)
- Keep the battery at a place that is out of reach of infants.
- Stop charging the battery if the charging is not completed even after exceeding the prescribed charging time and replace the battery. (EN-4)



Caution

Matters for preventing electrocution, fire disaster and malfunction of base unit



- A battery must be charged in an environment with the temperature in the range of 5°C to 35°C. (Risk of heating, generation of smoke, bursting and ignition of fire, as well as improper charging or deterioration of the battery.)
- Use and store the product in a location where there is little humidity or dust. (Risk of heating, ignition of fire or electrocution.)

送修或洽詢前，請先調查以下內容。

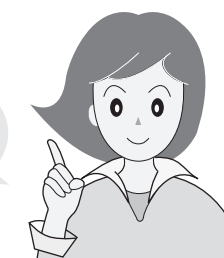

異常情況	調查內容	參考頁面	
過熱	主機運作時，溫度會上升至 40°C 左右，此為正常現象，並非異常。		
	主機發熱	● 圓筒形濾網與高性能折疊濾網是否堵塞？	CN-15·16
集塵筒組	充電期間的充電器與電池溫度極高。	● 這是因電流流過控制電路而產生熱能，屬於正常現象，並非異常。	—
	無法安裝至主機上。	● 集塵筒組的各零件組裝方式是否正確？	CN-16
	無法組裝集塵筒組。	● 集塵筒的底部有無累積過多垃圾？ ● 有無垃圾纏繞在圓筒形濾網上？ ● 高性能折疊濾網是否正確安裝在濾網盒上？ ● 集塵筒組的各零件組裝方式是否正確？	CN-14 CN-16 CN-16 CN-16
地板吸頭、旋轉刷	旋轉刷不會轉動。	● 將吸頭抬離地面時，為了確保安全，旋轉刷將會自動停止。（安全停止） ● 延長管是否與主機脫離？ ● 是否被毛髮或線頭等物品纏住？ ● 打掃地板吸頭緊密貼合地板或腳踏墊等物品時，可能會出現地板吸頭吸住不放，而觸動自動停止功能，導致旋轉刷停止。如遇此情況，請先關閉電源。解除自動停止功能後即可使用。 ● 地板吸頭的組裝方式是否正確？ ● 清潔踏墊和小型地毯等時可能有異物進入吸頭導致旋轉刷停止。這種情況下，請使用標準模式清潔。	CN-9 — CN-17 — CN-17 CN-9
	吸頭發出咔拉味拉的聲響。	● 這是因安全滾輪開關（安全停止機構）的構造特性所產生的聲音，絕非異常。	—
	異味	● 集塵筒內的垃圾是否已滿？（部分種類的垃圾可能會發出異味。） ● 以清水清洗圓筒形濾網與高性能折疊濾網後，是否充分讓其乾燥？【若在仍殘留水分的狀態下使用，將會產生異味。】	CN-13·14 CN-15·16
其他	高性能折疊式濾網上的白色濾紙。	● 看到高性能折疊濾網上的白色濾紙，此為正常現象，並非品質上的問題。	—

主機的清理濾網燈（紅色）與電池剩餘電力指示燈（綠色）同時閃爍時，可能是發生故障。請洽詢客戶服務中心。

故障時的檢查事項

異常情況	調查內容	參考頁面		
運作期間的主機異常	無法運作 (動作異常)	● 電池的剩餘電力是否已耗盡？敬請充電。 ● 電池是否正確安裝在主機上？ ● 請由主機上拆卸電池，靜待1分鐘左右後，再將電池裝回主機，重新進行操作。(主機電路將被重置，恢復成正常狀態。)	CN-7 CN-8 —	
	按下 OFF 時，不會立即停止運作。	● 按下 OFF 後的短暫期間，馬達會因慣性作用而轉動片刻，此為正常現象，並非故障。	—	
	運作時間變短。	● 電池會因反覆使用而導致運作時間逐漸縮短。充滿電後若仍僅能運作一段極短的時間，請更換電池。	CN-4	
	發出異常聲響	● 集塵筒組是否以正確的方式安裝在主機上？ ● 高性能摺疊式濾網與圓筒形濾網之間，有無混入垃圾或異物。	CN-14 CN-16	
	清理濾網燈 (紅色) 亮燈。 (CN-6)	● 集塵筒組的濾網有無過髒？請拆下集塵筒組並清理垃圾，再去除濾網上的污垢與灰塵。 ● 吸頭是否被堵住？(清掃踏墊時或使用附屬吸頭等情況) 請先按下 OFF 後，再讓吸塵機運作，指示燈即會熄滅。	CN-13-14 CN-15-16 CN-6	
	以「強力模式」運作時，吸力變弱。	● 在會受到陽光直接照射的地點或酷熱天氣的車內等高溫使用環境中，以強力模式連續運作時，主機可能會為了防止電池劣化而觸發過熱保護電路，導致吸力自動減弱。 ● 圓筒形濾網與高性能折疊式濾網是否堵塞？請用水清洗濾網。	CN-1 CN-15-16	
	中途停止 清理濾網燈 (紅色) 快速閃爍。 (CN-6) 吸力變弱 運作聲忽大忽小，或變得很大聲。	● 主機是否過熱？請於陰涼處放置片刻。 ● 電池的剩餘電力是否已耗盡？敬請充電。 ● 圓筒形濾網與高性能折疊式濾網是否堵塞？請用水清洗濾網。 ● 集塵筒內的垃圾是否已滿？ ● 有無面紙等大型垃圾纏繞在集塵筒內部？ ● 延長管與吸頭等處是否被垃圾堵住？請清除堵住的垃圾。	CN-6 CN-7 CN-15-16 CN-13-14 CN-13-14 —	
	採取上述處置後，仍出現吸塵機在清掃過程中停止運作的情況時，請洽詢客戶服務中心。			
	充電	無法充電 (充電器的充電指示燈 (紅色) 不會亮燈)	● 充電器的電源插頭是否確實的完全插入電源插座中？ ● 電池是否正確安裝在充電器上？ ● 充電器與電池的端子上，有無污垢或異物附著？請以乾布擦拭乾淨。	— CN-7 CN-17-18
		無法充電 (充電器的充電指示燈 (紅色) 快速閃爍)	● 可能是充電器故障或電池劣化與故障。請洽詢客戶服務中心。(在電池未充電的狀態下長時間放置未使用時，可能會導致電池劣化，必須更換電池。)	CN-6
充電器的充電指示燈 (紅色) 緩慢閃爍		● 在室溫 5°C~35°C 的環境中緩慢閃爍時，代表電池已屆更換時期。敬請更換電池。 ● 在低溫 (約 5°C 以下) 或高溫 (約 35°C 以上) 的環境中緩慢閃爍時，屬於正常現象，並非故障。請於 5°C~35°C 的環境中充電。	CN-4 —	

Tips

Precautions for Details

There may be cases where the floor surface is damaged when the roller switch on the bottom side of the Suction head, wheels or the Napped cushion is worn.

In the event the part becomes worn it is necessary to replace it with a new one. Stop using the product and contact your nearest service center approved by SHARP.

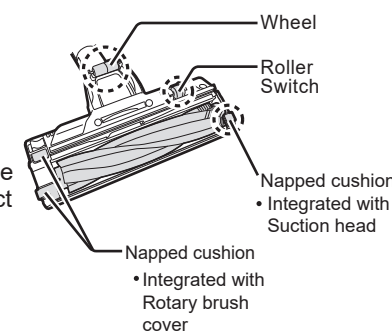

- The replacement of the part for the is performed while the product is left with Sharp.
- Replacement part (Rotary brush cover) is available for purchase.

Do not suction any of the following types of items (Risk of scratching of the product interiors and clogging of the product, as well as product malfunction).

- Liquid or moist dirt.
- Twines
- A large amount of sand.
- Sharp objects (glass, razor blade and the like).
- Large dirt or a large amount of dirt suctioned at the same time.

Clean respective filters when fine powder (plaster, cement, chalk and the like) has been suctioned. (EN-15 and 16)

Do not operate the product while the Dust cup assembly has been removed. (EN-5)

This product is for indoor use only.

Do not hit the Suction head hard on the steps on the floor surface or gaps in floor heights, as well as furniture or wall (Risk of the floor surface becoming scratched).

Do not apply lubricant to the Rotary brush (Risk of plastic parts cracking).

Do not drag the charger (Risk of scratching on the floor surface).

When the product is not used for a long time.

Remove the battery from the base unit and completely charge the battery before storing. (EN-7)

It is recommended that the power plug of the charger be removed from the power outlet. The charger consumes about 0.5 W of power while the power plug is connected to the power outlet. Removing the power plug when the charger is not in use can keep down wasteful power consumption.

Consider following precautions when storing the battery.

Do not transport or store the product together with any metal object, such as a needle, necklace or hair pin. Furthermore, store the product in a location where there is little humidity or dust. (Risk of heating, ignition of fire or electrocution.)

There are instances where the operation of the product causes noise to appear on the screen of television sets. There is no negative impact on the television set when this occurs.

This cordless vacuum cleaner is intended for household use and must not be used for commercial applications. Furthermore, the product must not be used for any purpose other than cleaning.

Replacing Battery

Batteries are consumable products. The operating time gradually becomes shorter as the battery deteriorates with repeated use. Although the deterioration of batteries vary depending on the condition of use or operating environments, the battery should be replaced if any of the following conditions apply.

- When the operating time is extremely short even when the battery has been charged.
- When the Charging lamp (red) of the charger blinks slowly whenever charging in an environment with room temperature of between 5°C and 35°C.

Recommended time for replacing the battery. (EN-6)

There is no malfunction if the the Charging lamp (red) on the charger blinks slowly when charging in an environment with a low temperature (about 5°C or lower) or a high temperature (about 35°C or higher). Charge the battery in an environment that is between 5°C to 35°C.

We invite you to recycle the spent battery.

The battery (lithium-ion battery) is a precious resource that can be recycled. Bring in the spent battery to a store that accepts batteries for recycling, rather than disposing of them as waste material.

Information on handling of spent battery.

Insulate the terminal sections using plastic tape or the like that are available on the market. Furthermore, do not disassemble the product.

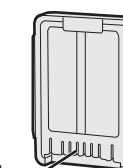

Terminal

PART NAMES

Names of each part and how to assemble

When using the product in the Stick state

● Press Release button to remove respective parts.

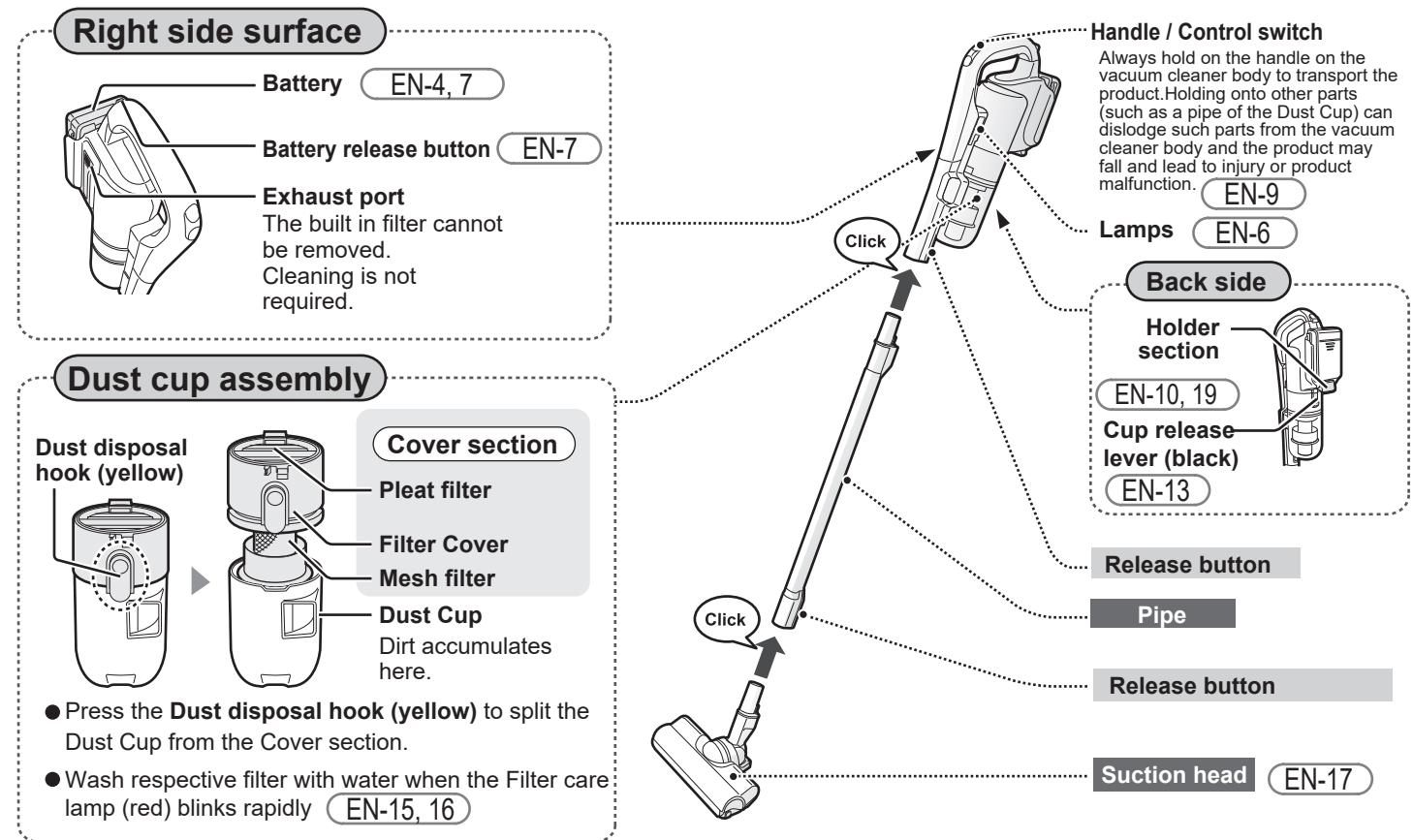

Accessories

The Suction head and Pipe described above are also accessories.

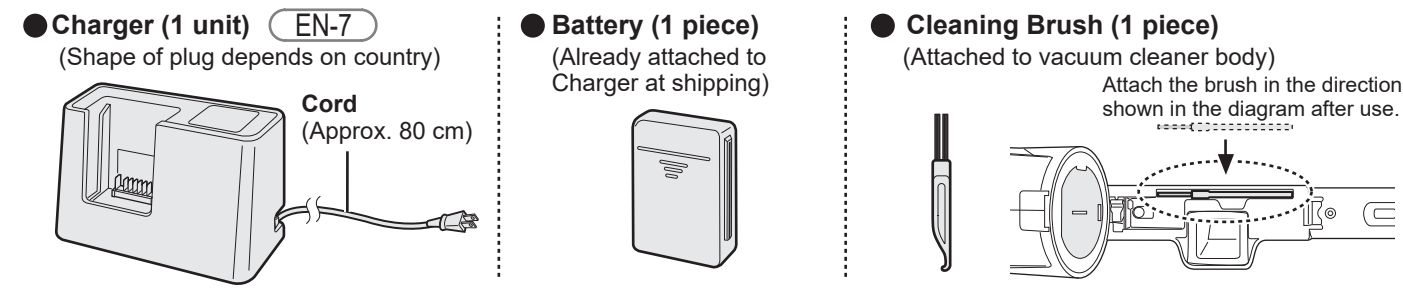

Enclosed Nozzles (EN-11, 12)

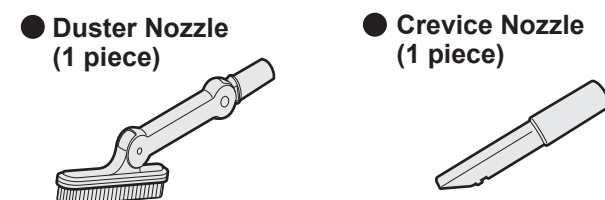

規格

電 源	輸入：100V-240V~ 50-60Hz (充電器)
電 源 方 式	充電式 (二次鋰電池組、18V ---)
耗 電 量	充電中：約 40W / 充電完成後：約 0.5W
最長連續運作時間*	強力模式：約 8 分鐘 標準模式：約 30 分鐘
集 塵 容 量	0.13L
充 電 時 間	約 80 分鐘 (可能會因環境溫度、使用時間等因素，最長需充電至 2 個小時左右。)
重 量	1.5kg (包含地板吸頭、延長管、主機、電池) 0.6kg (充電器)
主 機 尺 寸	寬222mm×長220mm×高980mm
充 電 器 尺 寸	寬200mm×長90mm×高133mm
電 線 長 度	80cm (充電器)

*使用 1 個電池的情況 (完全充滿電、電池使用初期 / 20°C)。會因地板材質、使用環境、使用狀態而改變。

收納

收納方式

注意！

- 請確認周圍有無容易損壞的物品。尤其應注意避免嬰幼兒與寵物靠近。
- 地板或家具等物品過於平滑，無法扣住時，請勿強行扣住，請以分解的方式收納。
- 部分種類的牆壁與家具，可能會因為固定墊摩擦而變髒，請多加注意。
- 直接靠在牆上時，可能會翻覆，請多加注意。

- 請於牆壁與家具間的縫隙、房間牆角、衣櫃內等不易傾倒的地點，以將固定墊扣住家具等物品的方式，進行收納。

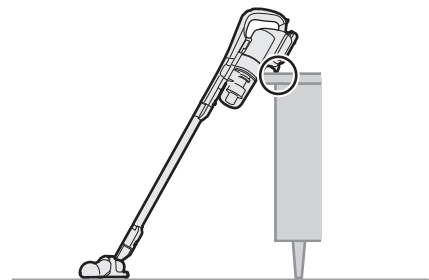
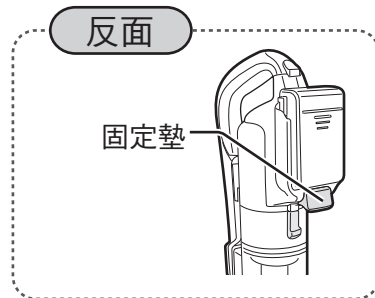
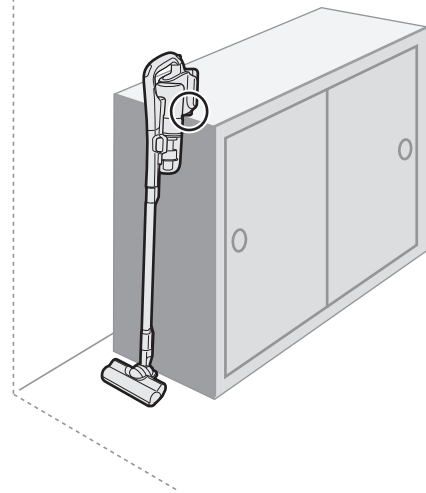

- 長期間不使用時，請先調整成下圖中的狀態後，再行收納。

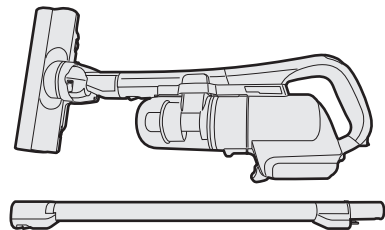

When using the product in the Handy state

- Press Release button to remove respective parts.

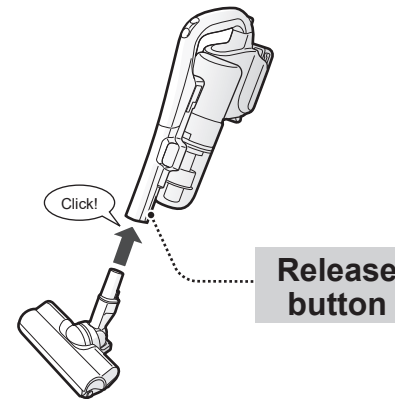

Tips for making the battery last

Charge the battery every time the product is used, regardless of how long it was used.

- The battery lasts longer when charged before the charge level becomes low.
- Leaving a discharged battery without charging will lead to the deterioration of the battery.



When the product is not used for a long time **EN-4**

Recommended Time for replacing the battery About 1,100 times of charge/discharge ◆

◆ According to tests conducted based on Sharp's standard for repeatedly charging and charge/discharge a battery. The life of a battery can vary depending on the conditions of use and the environment.

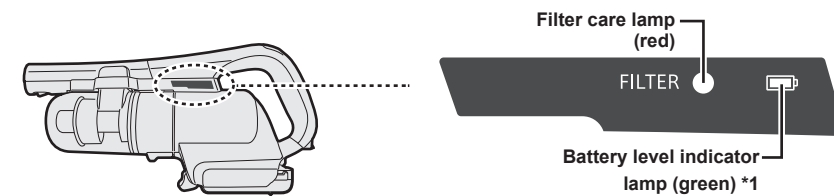
Lamps notify status of the vacuum cleaner body



Lamp State	Indicated State/ Explanation
Filter care lamp (red) 	Turned on *2 Empty the dust cup and clean the filter. EN-13, 14 The filter of the Dust cup assembly is dirty.
	Fast blinking Clean the filter by rinsing with water. The filter of the Dust cup assembly is clogged with dust. EN-15, 16 The vacuum cleaner body is overheating. Leave the product in a cool place for a while. Operating the product without allowing it to cool leads to the overheating protection circuit of the vacuum cleaner body triggering, which disables the product for some time.
Battery level indicator lamp (green) 	Turned on There is sufficient charge remaining in the battery.
	Blinking The charge remaining in the battery is low.
	Fast blinking The charge remaining in the battery is quite low. (There is no charge remaining in the battery.) Charge the battery. EN-7

*1 The Battery level indicator lamp is turned on in following situations. (The lamp is not turned on when there is no charge left in the battery.)

- About 5 seconds after the battery is reinstalled on the vacuum cleaner body.
- While using the product for cleaning
- About 5 seconds after pressing the OFF and stopping the operation of the product.

*2 The lamp may also turn on when the Suction head is clogged even when the filter is not dirty. In such instances, press the OFF and then restart operation to turn the lamp off. (The lamp goes off in about 10 seconds after the machine is stopped.)

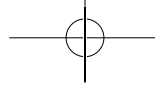

PREPARATION

See **EN-6** for tips for making the battery last.

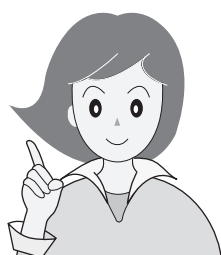

警告

- 保養時請務必遵守以下事項。
- 主機需按下 **OFF** 停止運作後，再拆下電池。
- 充電器需將電源插頭拔出。

【否則將造成觸電或受傷事故】

Charging battery

The battery is not charged when the product is purchased, so the battery must be removed from the vacuum cleaner body and charged until the Charging lamp on the charger is turned off.

1 Remove the battery from the vacuum cleaner body.

- Press the Battery release button in the direction of the arrow
- Remove the battery by sliding it in the direction of the arrow.

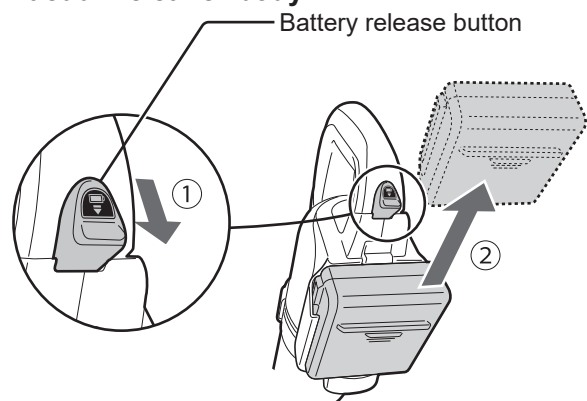

2 Insert the power plug of the charger in the power outlet.

(Shape of plug depends on country)

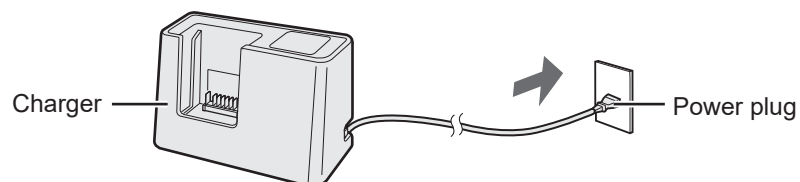

3 Set the battery on the charger and recharge.

Align the terminals.

Insert securely to as far as it goes.

Verify that the Charging lamp (red) is turned on.

- If the lamp blinks (repeating the "blinking" in intervals of about one second) the battery has not been securely inserted. Insert the battery securely to as far as it goes.

Lamp state	Charging status	Estimated duration from start of charging*
Turned on	Charging	-
Turned off	Charging completed (fully charged)	About 80 minutes

* The estimated duration of time required for charging varies depending on the remaining charge in the battery at the time charging starts.

Notices

The charger or the battery becomes hot while charging, but this is not abnormal.

CAUTION

Do not touch the terminals of the charger or the battery since they become hot while charging or immediately after completing charging. [Risk of burns.]

注意!

- 請勿使用清潔劑、稀釋劑、揮發油、以及熱水（約 40°C 以上）。【否則將造成變質或變形】
- 請避免吹到吹風機等機器的熱風。【否則將造成變形或故障】

安裝

- 將旋轉刷無齒輪的一方插入溝槽最深處。

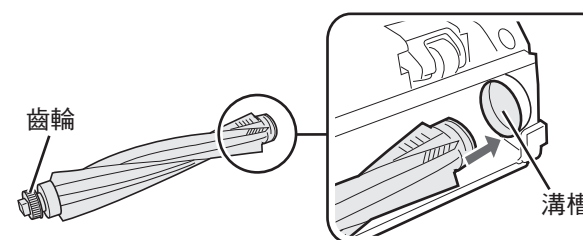

- 將皮帶套住旋轉刷的齒輪，並放入溝槽中。

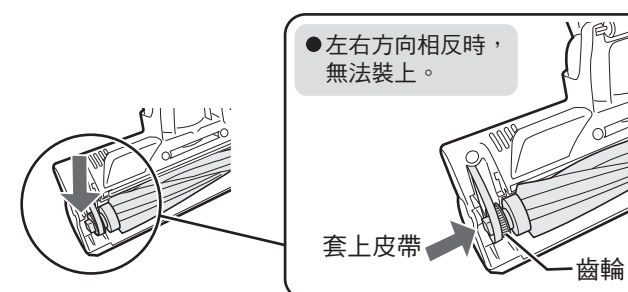

- 將刷頭保護蓋的扣爪扣住溝槽進行安裝。

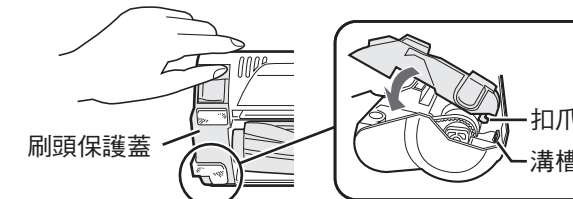

- 將開關拉桿朝箭頭指示方向滑動。

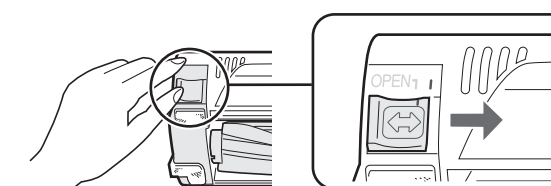

充電部位的接點 (端子)

以乾布擦拭污垢。

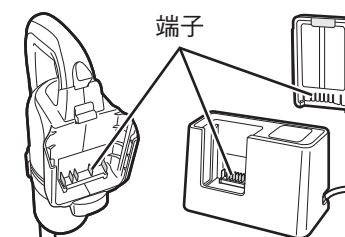

保養

地板吸頭、主機、附屬吸頭、
充電部位的接點（端子）

地板吸頭（旋轉刷）

被線頭、橡皮筋、毛髮、寵物的毛等物質纏住時。

清除垃圾

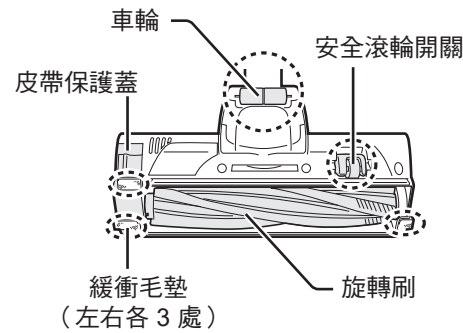

使用除塵毛刷吸頭吸取附著在吸頭上的灰塵，並將纏繞在○部位的毛髮與線頭剪下後，以用力擰乾的濕布擦拭。

附著於窄小部位中的垃圾，請使用細長型剪刀或鑷子等工具去除。

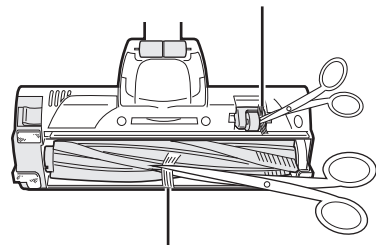

沿著旋轉刷的溝槽剪下。
（不可剪到刷毛的毛尖。）

○部位已磨損時，請停止使用，並確認
CN-4 的內容後，洽詢客戶服務中心。

水洗 髒污非常嚴重時

拆下旋轉刷用水清洗後，將水分徹底瀝乾，並放置於通風處充分風乾後，再裝回主機。

不可將整個吸頭水洗。

拆下

① 將開關拉桿滑動至「OPEN」處，拆下皮帶保護蓋。

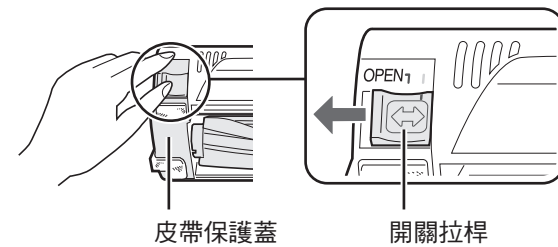

② 在將旋轉刷抬高的狀態下，將皮帶由齒輪上拆下，並拆卸旋轉刷。

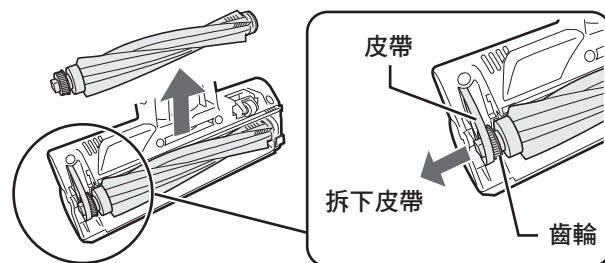

主機、附屬吸頭、充電部位的接點（端子）

感覺已髒污時

主機

以含有清水或稀釋的中性清潔劑的抹布擦拭。請勿使用稀釋劑與揮發油類。
【否則將造成變質或變色】

注意！

● 主機、充電器、電池不可水洗。

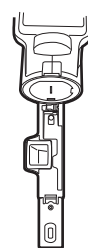

附屬吸頭

使用清水或稀釋過的中性清潔劑清洗。

請先水洗後，再充分去除水分。 CN-16

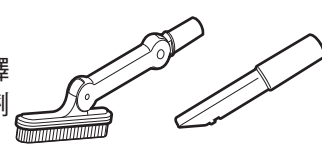

Insert the battery into the vacuum cleaner body.

① Remove the battery from the charger.

② Insert the battery into the vacuum cleaner body.

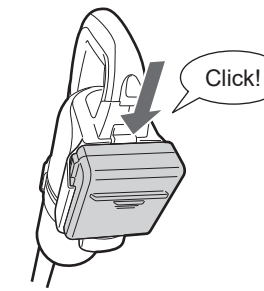
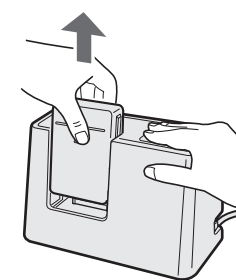

Securely insert the battery along the grooves on the vacuum cleaner body until the "click" sound is emitted.

● Once the terminals are connected, the Battery Level Indicator lamp on the vacuum cleaner body turns on for about five seconds to notify the remaining charge in the battery. Be sure to securely insert the battery until the "click" sound is heard, even if the lamp starts to light up during the process.

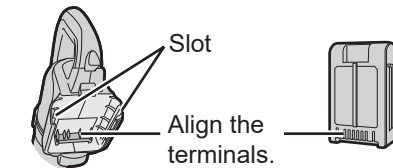

Notices

In cases where charging is not possible, verify followings.

- Is the power plug of the charger dislodged?
- Is there any dirt or foreign matter attached to a terminal of the charger or the battery? Remove the dirt or foreign matter with dry cloth. EN-17, 18
- Is the battery correctly set to the charger?

Information on Charging

- The charging time may be long in following cases.
 - When not in use for long period of time
 - The battery is charged in an environment at a low temperature (approx. 5°C or lower) or a high temperature (approx. 35°C or higher) (charge the battery in an environment with at room temperature between 5°C and 35°C).

Information on operating time

- The operating time gradually becomes shorter as the battery is used repeatedly.
- When the remaining charge in the battery becomes low, the Battery level indicator lamp (green) blinks to notify the status. EN-6

Continuous operation time*	
High mode	About 8 minutes
Standard mode	About 30 minutes

※ When a single battery is used (fully charged and initial condition of the battery / 20°C). Conditions may vary depending on the material of the floor surface, environment in which the product is used and the condition under which the product is used.

The Charging lamp (red) of the charger blinks slowly

- If the blinking occurs when the room temperature is between 5°C and 35°C, then it is time to replace the battery. EN-4
- There is no malfunction if the product blinks in an environment with a low temperature (about 5°C or lower) or a high temperature (about 35°C or higher). Charge the battery in an environment that is between 5°C to 35°C.

(When the Charging lamp (red) of the charger rapidly blinks, that may be caused by malfunction of the charger, or deterioration or malfunction of the battery. Contact your nearest service center approved by SHARP.)

VACUUMING 1

Flow of cleaning process

Control switch

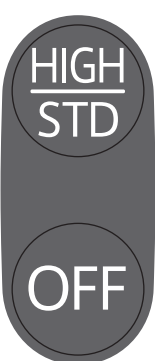

Start



The mode toggles between the "High mode" and the "Standard mode" each time it is pressed.

High mode: When cleaning with maximum suction power.

Standard mode: When cleaning with subdued suction power. (When a mat or a rug tends to block the Suction head, for instance.)

Finish



Cleaning completed

Charging the battery EN-7

Disposing of dirt is recommended after each cleaning session, for the purpose of hygiene. EN-13, 14

Notices

- The Rotary brush of the Suction head automatically turns when the cleaning starts.
- Even when a cleaning session is completed in the Standard mode, the operation starts with the High mode if the **HIGH STD** is pressed the next time.
- When the remaining charge in the battery becomes depleted while operating, the operation is automatically stopped to prevent excessive discharge that can deteriorate battery. Always charge the battery each time the product is used for cleaning, regardless of how long it was used.
- During the cleaning of mats or rugs, the Suction head may get stuck to the material and the Rotary brush may stop. In this case, continue cleaning in Standard mode.

Safety Stop

The Rotary brush stops automatically for safety purpose when the Suction head (roller switch on the bottom side EN-17) is off the floor while cleaning. The operation does not stop in such instances. The rotation restarts when the Suction head contacts the floor and moved.

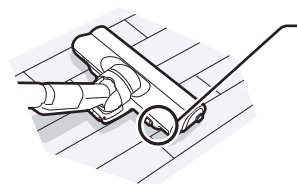

Even when the Suction head contacts the floor if the Roller Switch is off the floor the operation is temporarily suspended.

CAUTION

- Do not touch the Rotary Brush or Roller Switch while the operation is temporarily suspended. [Risk of injury when the Rotary brush starts to operate] Be sure to press the **OFF** to stop the operation when cleaning the Suction head.

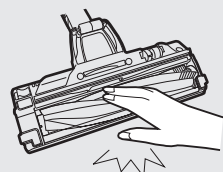

可水洗的物品

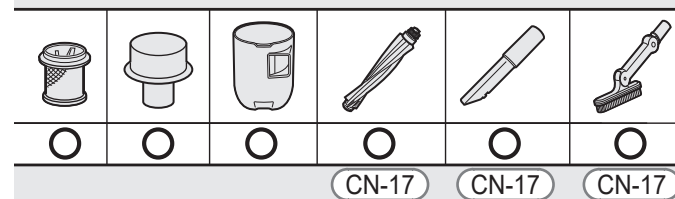

保養

摺疊濾網

將垃圾與灰塵敲落。

垃圾常會累積於內側，請依照右圖的方向敲擊。

- 請勿使用清潔刷。【否則可能造成破損】

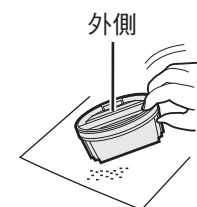

圓筒形濾網（上/下）、濾網盒

以清潔刷去除垃圾與灰塵。

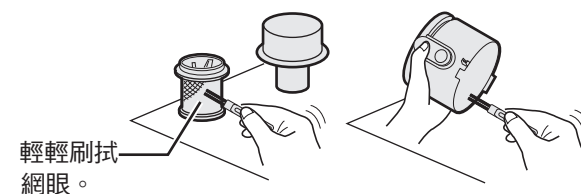

髒污非常嚴重時請水洗。

摺疊濾網（藍色）

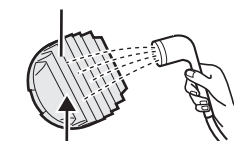

請仔細清洗內側。

- 若對異味及髒污比較在意的話，可以用50°C以下的水浸泡1-2小時後，再進行清洗。

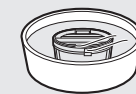

使用清水或稀釋過的中性清潔劑清洗。

濾網盒

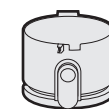

圓筒形濾網

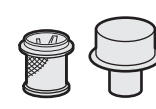

集塵筒

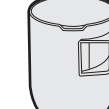

請先水洗後，再充分去除水分。

- 充分去除水分後，再進行組裝。【保養後仍無法改善濾網堵塞情況的原因】
- 請確實瀝乾水分，並以毛巾等輕柔擦乾水分後，放置於通風良好處陰乾，讓其充分乾燥。【發生異味與故障的原因】

風乾時間參考值：12小時
(會因環境或季節而改變)

- 不可吹到吹風機等機器的熱風。【否則將造成變形或故障】

警告

- 保養時請務必遵守以下事項。
- 主機需按下 **OFF** 停止運作後，再拆下電池。
- 充電器需將電源插頭拔出。

【否則將造成觸電或受傷事故】

組裝

1 安裝濾網盒與圓筒形濾網（上/下）。

對準位置

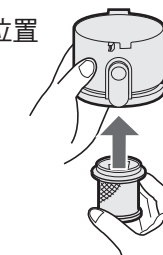

轉動

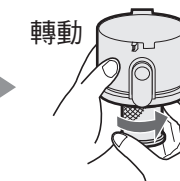

對準位置

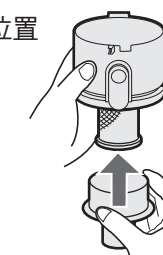

轉動

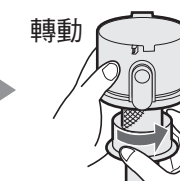

2 將摺疊濾網的卡榫對準濾網盒的卡槽後，將其推入。

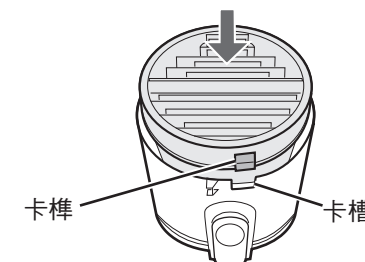

- 請先確認圓筒形濾網內確實無垃圾與異物後，再進行安裝。【發生異常聲響的原因】

3 安裝集塵筒。

將集塵筒的突起處對準垃圾清理鍵（黃色）後，將其推入。

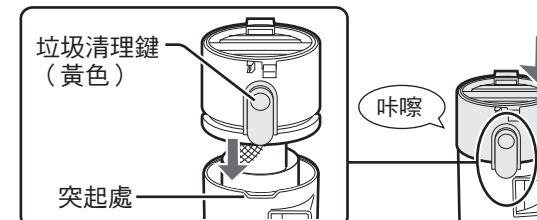

注意！

- 未正確組裝各零件時，將無法安裝至主機上。
- 清理垃圾或保養時，請注意避免遺失圓筒形濾網（上/下）。

保養

集塵筒組

進行保養的時候

如有以下情況，請去除濾網中的垃圾與灰塵。

■ 清理濾網燈（紅色）亮燈時*

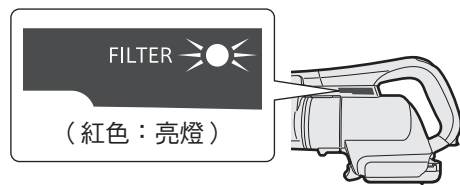

- 運作中途停止時
- 吸力變弱時
- 運作聲忽大忽小，或變得很大聲時。

如有以下情況，請用水清洗濾網。

★ 清理濾網燈（紅色）快速閃爍時

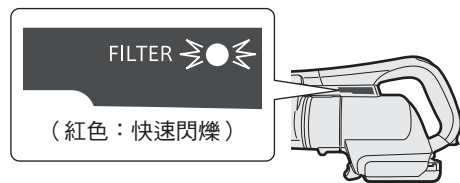

- ★ 主機過熱時
- ★ 吸塵機吸入細微粉末類物質時
- ★ 清理濾網燈（紅色）頻繁亮燈時

- 充分保養濾網後，清理濾網燈（紅色）仍快速閃爍時，請購買選購品中的摺疊濾網，並進行更換。

※ 吸頭被堵住時（清理踏墊或使用附屬吸頭等情況），即使濾網並不髒，亦可能會亮燈。如遇此情況，請先按下 OFF 後，再讓吸塵機運作，指示燈即會熄滅。

重要須知

- 在未進行保養的情況下讓其繼續運作時，將自動停止。請務必保養。
- 請先鋪上報紙等物品後，再進行保養。
- 請勿使用稀釋劑、揮發油、以及熱水（約 40°C 以上）。

拆下

1 拆下集塵筒。

- ① 按下垃圾清理鍵（黃色）。
- ② 握住濾網盒部位向上抬高

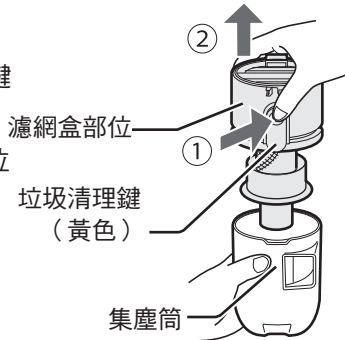

2 拆下摺疊濾網。

- ② 握住握把向上抬高

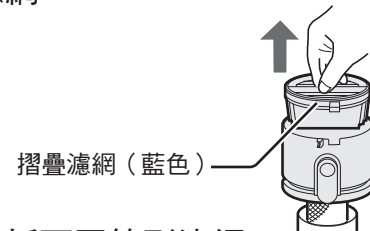

3 以轉動方式拆下圓筒形濾網（上/下）。

- ③ 濾網盒
- ③ 圓筒形濾網（上）
- ③ 圓筒形濾網（下）

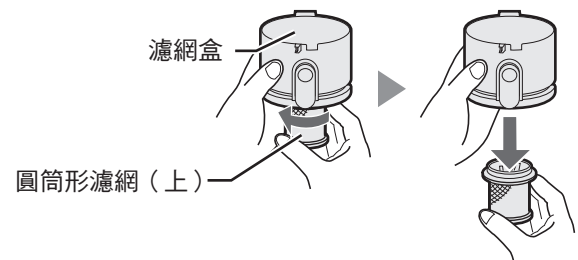
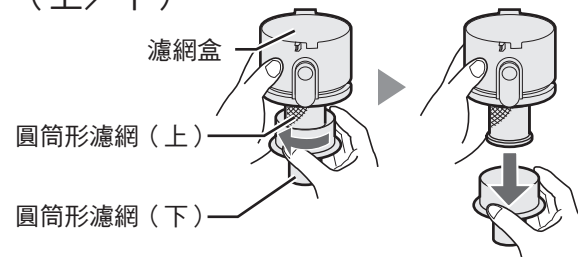

- 圓筒形濾網（上/下）的拆解順序，可能會因嵌合的狀態而改變。

- 使用清潔刷的握柄輕拍高性能摺疊式濾網的頂端部位（塑膠）時，可藉由震動將垃圾與灰塵彈落，簡化保養作業。

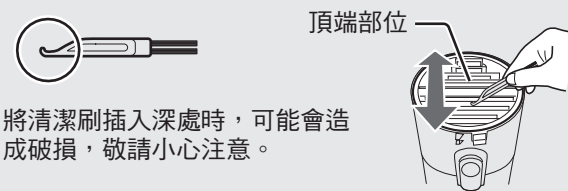

- 將清潔刷插入深處時，可能會造成破損，敬請小心注意。

Tips for Vacuuming

- ★ Move the Suction head so that it moves **lightly and glides slowly**. More dirt is suctioned this way than quickly moving the Suction head back and forth. This also prevents scratching of the vacuum cleaner and the floor surface.



- For cleaning floors.

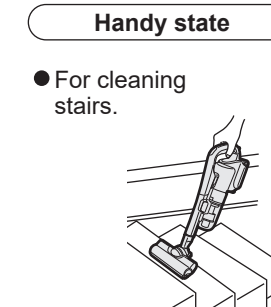

- For cleaning stairs.

CAUTION

- Always install the Suction head or an Accessory Suction head when cleaning. [Risk of scratching of floor surface or product malfunction]
- Do not clean while pressing the Suction head hard against the floor surface. The wheels and Napped cushions (EN-17) may wear quickly and scratch the floor surface.
- Moving the Suction head (wheel) sideways or diagonally can result in scratches and markings on the floor surface.
- There are instances where the rotation of the wheels deteriorate due to the entanglement of pet hair and the like on the wheels. Be sure to clean the wheels often. (EN-17)

The product can be left in the conditions depicted in the diagrams below when pausing the cleaning operation.

Resting the vacuum cleaner

Hook the holder section onto a table or the like.



Standing state

Hook the holder section on a chair or the like.

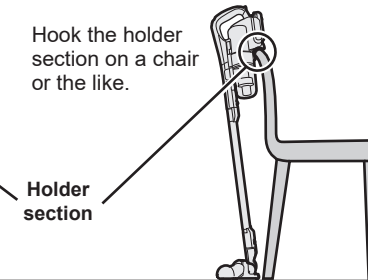

- Always press the OFF and stop the operation of the product.
- Place the product on a flat floor.

CAUTION

- Keep the Suction head contacting the floor surface when pausing the cleaning operation. [Risk of falling or tumbling of the product]
- Verify that there is nothing in the vicinity of the product that can be damaged easily when standing the vacuum cleaner body leaned on an object. Pay particular attention to ensure no infant or pet is allowed to get near the product.
- Do not leave the product while leaning on an object.

VACUUMING 2

Using accessory nozzles (Duster nozzle and Crevice nozzle)

Duster nozzle

- The accessory may be used by attaching on the vacuum cleaner body or on a pipe.
- For cleaning high places, such as above furniture.

Do not press the **OFF** while operating when cleaning with the vacuum cleaner body facing up.

Press the **OFF** after facing the Suction head downward to stop the operation.

Pressing the **OFF** while the product is facing up may lead to the dirt spilling out of the vacuum cleaner body.

Use

- Insert securely and use.

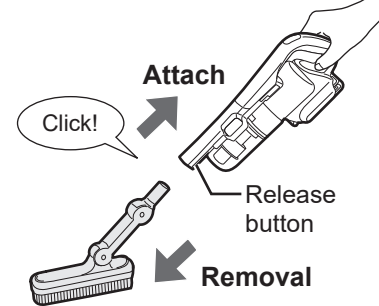

Turn while pressing the Lock Release to change the angle.

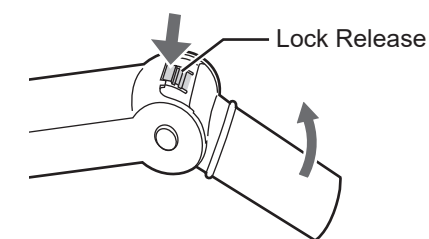

- Press the Release button for the vacuum cleaner body or the pipe to remove the accessory.

CAUTION

- Careful not to pinch a hand or a finger in the rotating section when changing the angle!

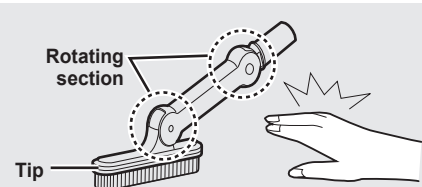

清理垃圾

1 拆下集塵筒清空垃圾。

- 1 按下濾網盒部位側面的清理垃圾鍵（黃色）。

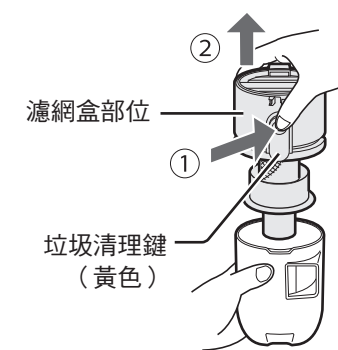

- 2 握住濾網盒部位向上抬高

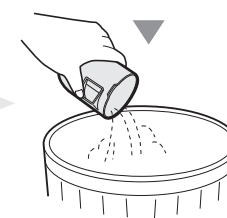

- 請確認集塵筒的底部是否無垃圾殘留。

2 以清潔刷清除圓筒形濾網上的垃圾。

- 無垃圾纏繞時
- 保養集塵筒組。
- CN-15、16



長期持續使用後

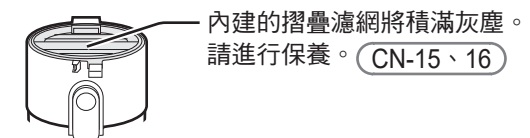

3 安裝集塵筒。

將集塵筒的突起處對準垃圾清理鍵（黃色）後，將其推入。

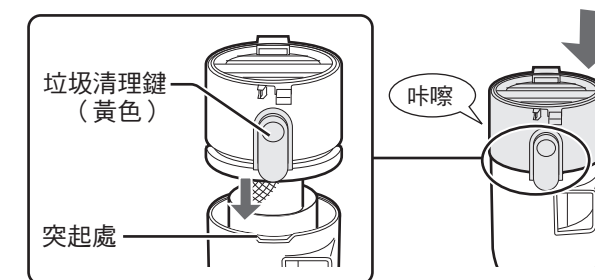

安裝

將集塵筒組安裝至主機上。

- 1 將集塵筒的卡槽部位扣住主機上的鈎扣（藍色）。

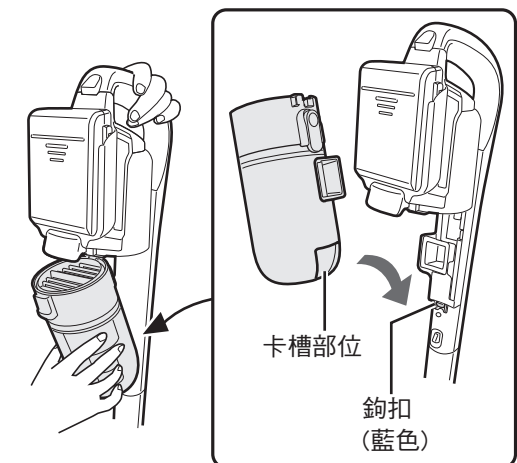

- 2 朝箭頭指示方向確實推入

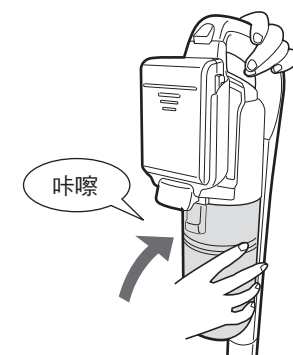

注意！

- 未將摺疊濾網安裝於集塵筒上時，無法安裝至主機上。
- 未將集塵筒組確實安裝於主機時，將引發吸力減弱、發出異常聲響、垃圾混入馬達中等故障。
- 集塵筒組必須事先組裝完成，否則無法確實安裝至主機上。
- 清理垃圾或保養時，請注意避免遺失圓筒形濾網（上/下）。

清理垃圾

需清理垃圾時

■累積的垃圾量接近「MAX」指示線附近時

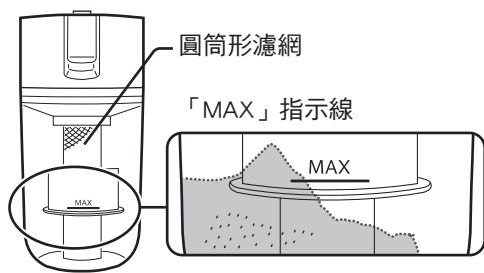

- 累積的垃圾不平均時，亦請在超出「MAX」指示線之前即加以清理。
- 基於衛生考量，建議每次清掃時皆清空垃圾。

■清理濾網燈（紅色）亮燈時*

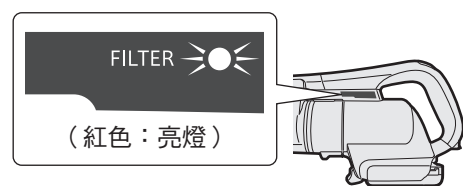

- 清空集塵筒內的垃圾後，請依照右側的順序，一併清理圓筒形濾網上的垃圾。採取以上措施後燈號仍未熄滅時，請進行保養。(CN-15、16)

※吸頭被堵住時（清理踏墊或使用附屬吸頭等情況），即使濾網並不髒，亦可能會亮燈。如遇此情況，請先按下 **OFF** 後，再讓吸塵機運作，指示燈即會熄滅。

重要須知

- 未清理垃圾即繼續運作時，將會使垃圾附著在圓筒形濾網上，造成吸力減弱。請務必清空垃圾。
- 未清空垃圾並繼續運作時，將引發故障。
- 清理垃圾的動作，請於報紙或垃圾桶等物品的上方進行。【垃圾可能會溢出】

拆下

同時將集塵筒組拆下。

- ① 在將主機垂直立起的狀態下，拉動集塵筒拆卸開關。

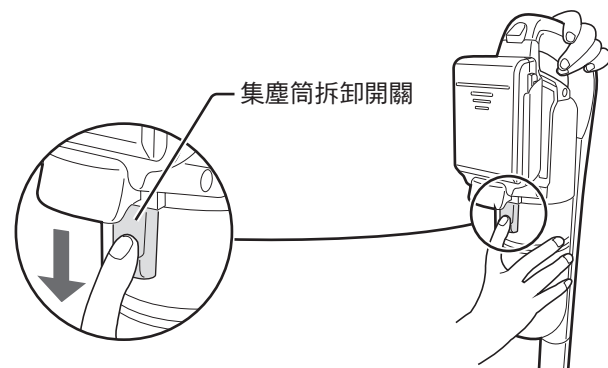

- ② 拆下

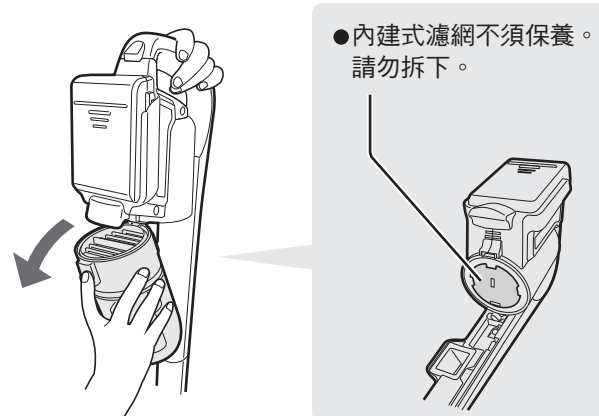

取出清潔刷

- 安裝於主機卡槽上。

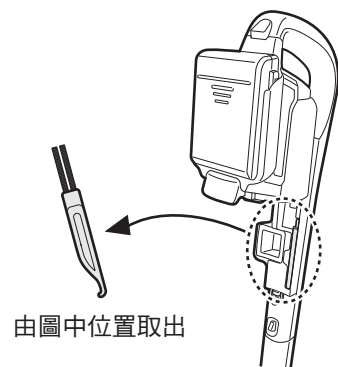

※ Do not use the product to clean items that scratch easily, such as a piano.

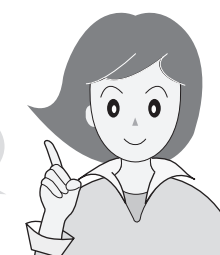

Crevice nozzle

- The accessory may be used by attaching on the vacuum cleaner body or on a pipe.
- For cleaning gaps between furniture and sash on the windows.

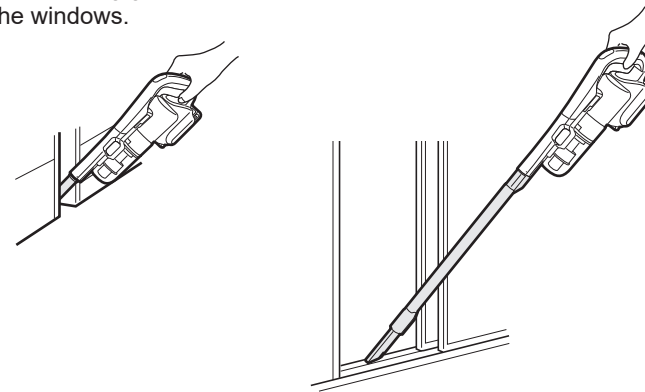

This is a hole intended to prevent overheating of the motor in an enclosure. Do not block the hole.

Use

- Insert securely and use.

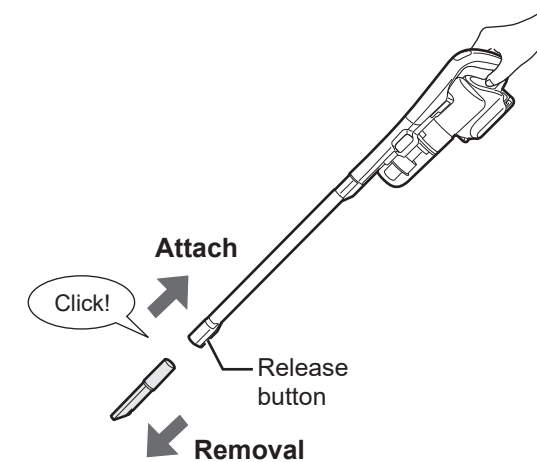
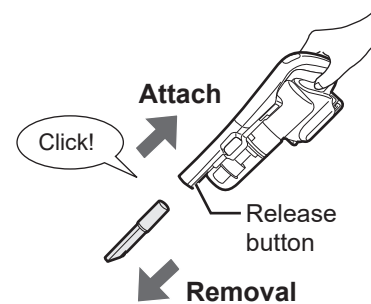

- Press the Release button for the vacuum cleaner body or the pipe to remove the accessory.

CAUTION ● Careful not to pinch a hand or a finger!

EMPTYING THE DUST CUP

Guide for disposing of dirt

■ When the level of the accumulated dirt reaches the "MAX" line.

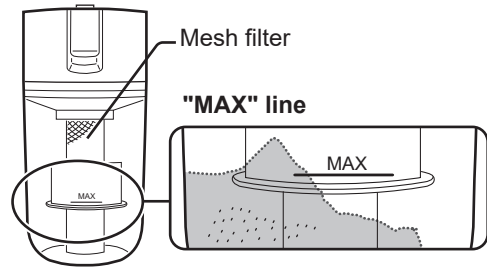

- Dispose of the dirt before the level of the accumulated dirt exceeds the height of the line, even when the dirt is leaning on one side or the other.
- Disposing of dirt is recommended after each cleaning session, for the purpose of hygiene.

■ When the Filter care lamp (red) is turned on*

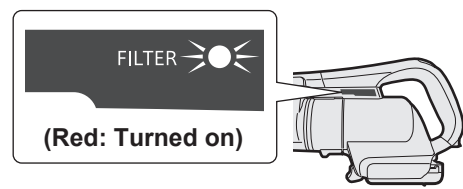

- Dispose of the dirt in the Dust Cup and follow the procedure described on the right to remove the dirt on the Mesh filter. If the lamp still does not turn off, clean the unit.

EN-15, 16

※The lamp may also turn on when the Suction head is blocked (when cleaning a mat or when using an enclosed nozzle and the like) even when the filter is not dirty. In such instances, press the **OFF** and then restart operation to turn the lamp off.

Tips

- Continuing to operate the product without disposing of the accumulating dirt results in the deterioration of the suction power due to the attachment of the dirt on the Mesh filters. Be sure to dispose of the dirt. Continuing to operate the product without disposing of the dirt may lead to the product malfunction.
- Dispose of the dirt on newspapers or over a dirt bin. [Dust could spill out]

Removal

Removing the Dust cup assembly

- ① Pull the Cup release lever while standing the vacuum cleaner body vertically.

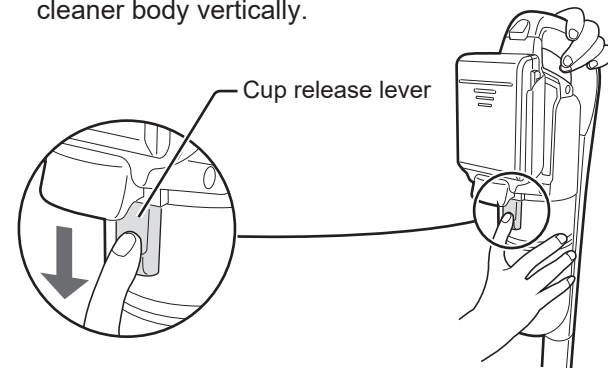

- ② Removal

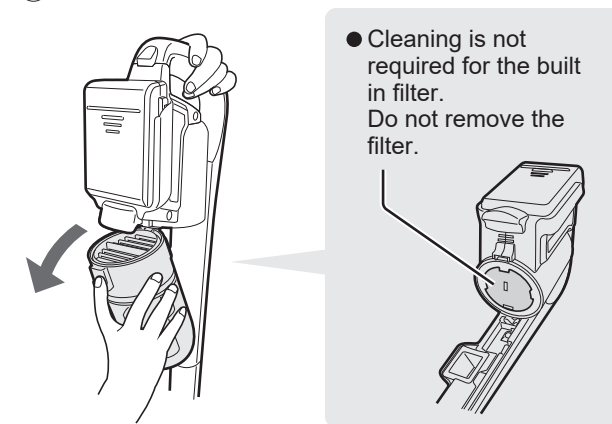

- Cleaning is not required for the built in filter. Do not remove the filter.

Removing the Cleaning Brush

- It is on the vacuum cleaner body side after the Dust cup assembly has been removed.

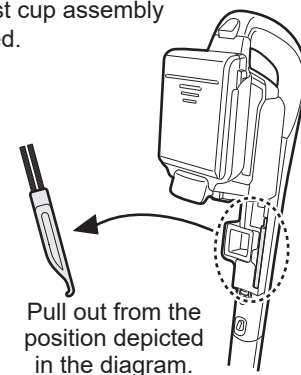

Pull out from the position depicted in the diagram.

※請勿用於清掃鋼琴等容易刮傷的物品。

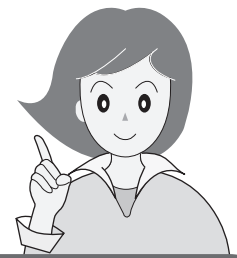

狹縫吸頭



- 可安裝於主機或延長管上使用。
- 適用於清掃家具之間的縫隙及窗框等處。

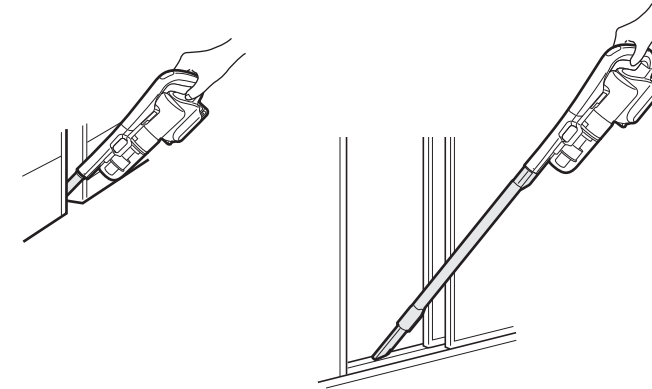

避免馬達因密閉而過熱的開孔。請勿將其堵住。

使用

- 請確實插入後再使用。

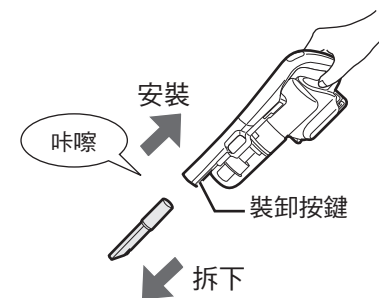

安裝
拆下

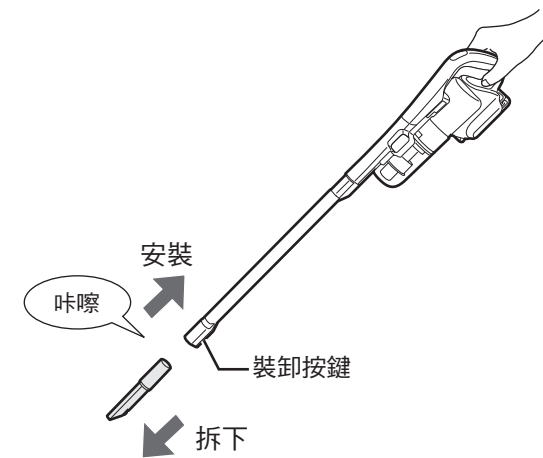

安裝
拆下

- 請同時按住主機或延長管上的裝卸按鍵拆下。

注意！ ● 請避免手掌或手指被夾傷。

操作方法 2

使用附屬吸頭時 (除塵毛刷吸頭、狹縫吸頭)

除塵毛刷吸頭

- 可安裝於主機或延長管上使用。
- 適用於清掃家具上方等高處。

以主機朝上的方式清掃時，運作期間請勿按下 OFF。

要停止運作時，請先將吸頭朝向下，再按下 OFF。

在朝向上方的狀態按下 OFF 時，垃圾可能會由主機上掉落。

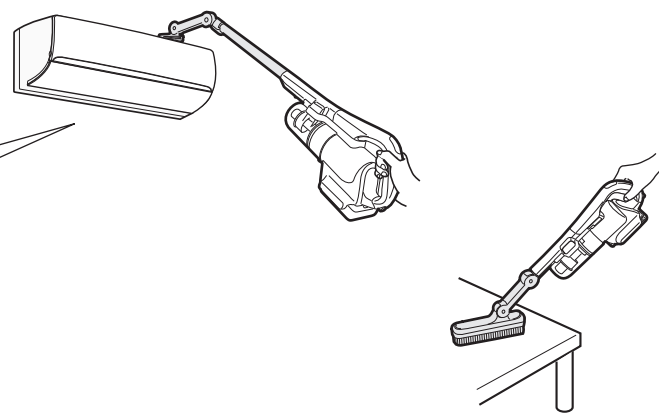

使用

- 請確實插入後再使用。

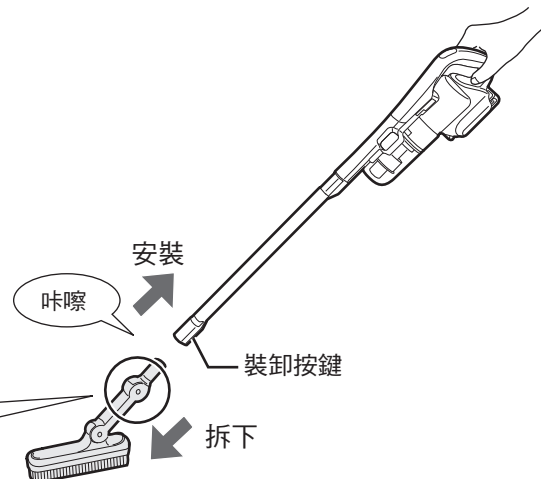

要改變角度時，請按住卡榫並同時轉動。

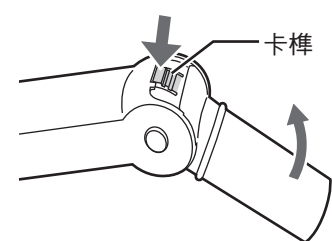

- 同時按住主機或延長管上的裝卸按鍵拆下。

注意!

- 改變角度時，請注意避免手掌或手指被旋轉部位夾傷。

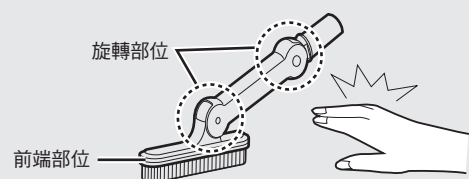

Emptying the Dust Cup

1 Remove the Dust Cup and dispose of the dirt.

- ① Press the Dust disposal hook (yellow) on the side of the Cover section.

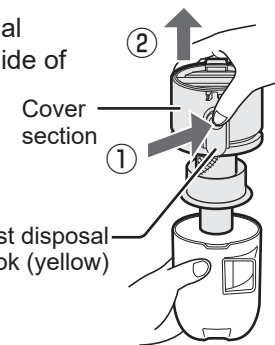

- ② Lift the Cover section.

- Ensure that no dirt remains at the bottom of the Dust Cup.

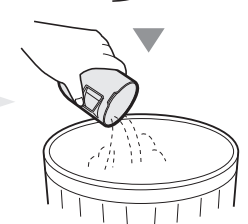

2 Remove dirt on the Mesh filters with a cleaning brush.

When the dirt is entangled and does not come off

- Clean the Dust cup assembly.

EN-15, 16

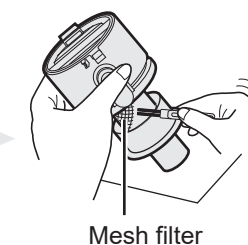

When used continuously for long time

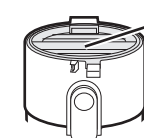

Dust accumulates on the built in Pleat Filter. Clean this dust out.

EN-15, 16

3 Mount the Dust Cup.

Align the protrusion on the Dust Cup and the Dust disposal hook (yellow) and insert.

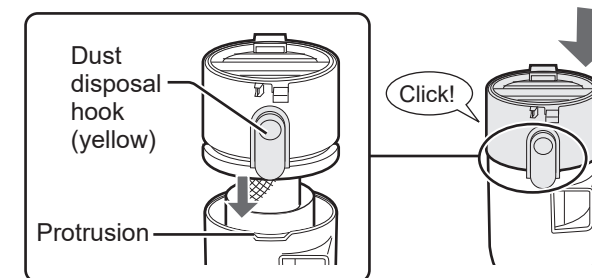

Mounting the Dust Cup Assembly

Install the Dust cup assembly on the vacuum cleaner body.

- ① Put the recessed section on the Dust Cup to the hook (blue) on the vacuum cleaner body

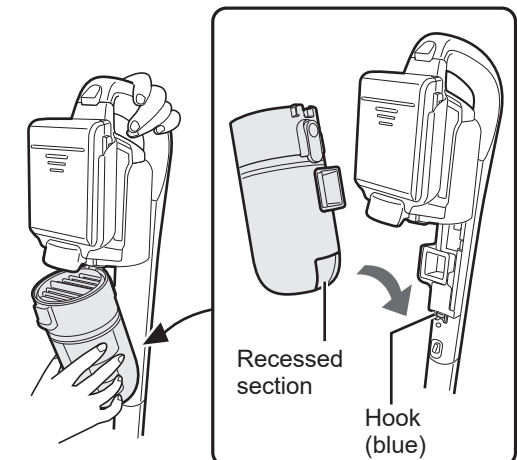

- ② Securely push in the direction of the arrow

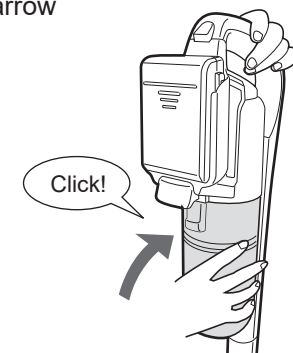

CAUTION

- The Pleat filter cannot be installed on the vacuum cleaner body unless it is installed on the Dust Cup.
- The suction power may decline, abnormal noise may be heard, dirt may enter into the motor and other issues may arise that may lead to product malfunction unless the Dust cup assembly is securely installed on the vacuum cleaner body.
- The Dust cup assembly cannot be installed properly on the vacuum cleaner body unless it is completely assembled.
- Caution is required to ensure that the Mesh filters (Upper and Lower) are not lost while throwing out dirt or cleaning.

MAINTENANCE

Dust cup assembly

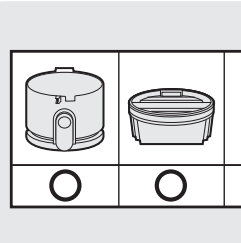

Guide for cleaning

Dispose of dirt and remove the dirt and dust on the filter in following cases.

■ When the Filter care lamp (red) is turned on*

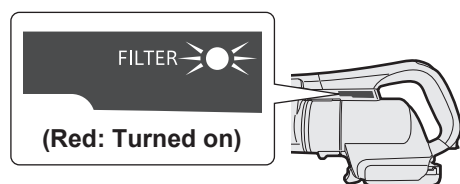

- The product stops during operations
- When the suction force is weak
- The operating sound changes or becomes louder

Clean the filter by rinsing with water in following cases.

★ When the Filter care lamp (red) is rapidly blinking*

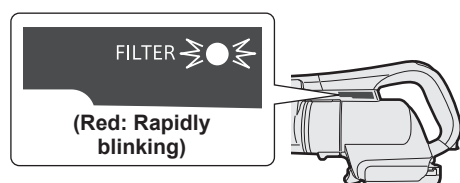

- ★ When the vacuum cleaner body is heated.
- ★ When fine powder has been suctioned
- ★ When the Filter care lamp (red) turns on frequently.

- If the Filter care lamp (red) rapidly blinks even after the filter has been sufficiently cleaned, purchase a Pleat filter and replace the filter.

※ The lamp may also turn on when the Suction head is blocked (when cleaning a mat or when using an enclosed nozzle and the like) even when the filter is not dirty. In such instances, press the **OFF** and then restart operation to turn the lamp off.

Tips

- Continuing the use without cleaning will lead to automatic stop of the operation. Cleaning of the filters must be performed.
- Lay down newspapers and the like when cleaning the filters.
- Do not use any paint thinner, benzene product or hot water (exceeding approx. 40°C).

Removal

1 Remove the Dust Cup.

- ① Press the Dust disposal hook (yellow).
- ② Lift the Cover section.

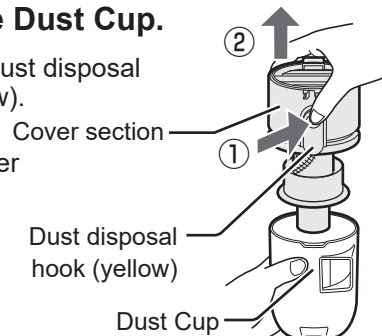

2 Remove the Pleat filter

Hold on the handle to lift.

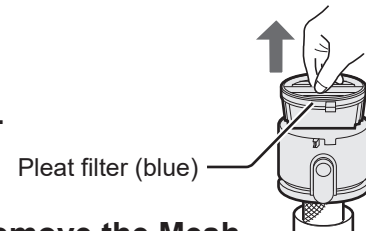

3 Turn and remove the Mesh filters (Upper and Lower).

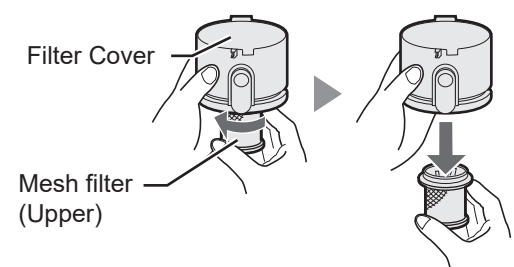
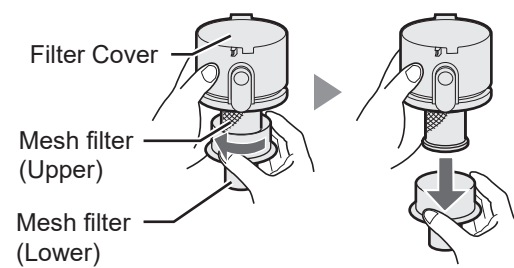

- The Mesh filters (Upper and Lower) may have different sequence for removal, depending on how they are matched.

- Use the hand grip on the cleaning brush to tap on the raised section (plastic) of the Pleat filter to dislodge dirt and dust with vibration for easier cleaning.

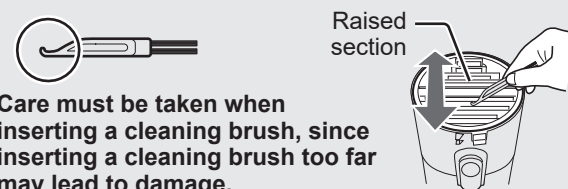

- Care must be taken when inserting a cleaning brush, since inserting a cleaning brush too far may lead to damage.

清掃要訣

- ★ 以讓吸頭緩慢地輕輕滑動的方式移動。與快速前後移動的方式相較，可更有效地吸入垃圾，並且防止吸塵機或地板刮傷。
- ★ 挺直背部，減少身體負擔。
- ★ 清掃榻榻米時，需沿著縫隙移動。

直立狀態

- 適用於清掃地板。

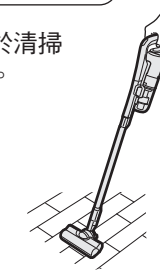

手提狀態

- 適用於清掃樓梯。

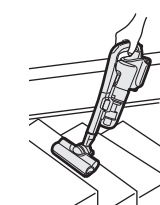

注意！

- 清掃時請務必裝上地板吸頭或附屬吸頭配件。【否則可能造成損傷或故障】
- 請勿將吸頭用力頂住地板清掃。否則恐造成車輪與緩衝毛墊 (CN-17) 加速磨損，導致地板刮傷。
- 將地板吸頭 (車輪) 朝側面或斜向移動時，可能會造成地板刮傷或留下痕跡。
- 杉木、日本扁柏、松木、塑膠地板等容易刮傷的地板，以及使用地板蠟、塗裝劑後的地板，可能會因吸頭移動而造成刮傷。尤其請避免將吸頭用力頂住地板移動，或是持續在相同位置運作。
- 因移動吸頭而導致新建築物等上蠟的地板光澤出現落差時，請使用乾的抹布擦拭後，再次上蠟並讓其乾燥。
- 寵物毛髮可能會纏繞在車輪上，導致車輪轉動不良。請頻繁保養。(CN-17)

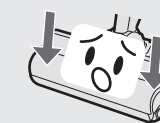

要暫停清掃時，可放置成下圖中的狀態。

斜靠的狀態

將固定墊斜靠在桌子等物品上。



扣住的狀態

將固定墊扣住椅子等物品。

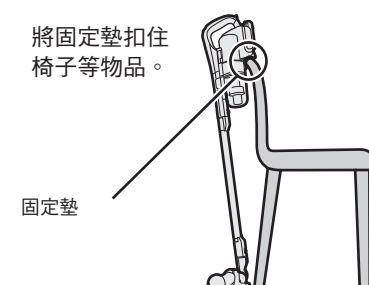

- 請務必先按下 **OFF** 停止運作。
- 請放置於平坦的地板上。

注意！

- 要暫停清掃時，請將吸頭調整成與地面貼合的狀態。【否則將使其掉落或傾倒】
- 以斜靠方式放置主機時，請確認周圍有無容易損壞的物品。尤其請注意避免嬰兒與寵物靠近。
- 請勿長時間以斜靠的方式放置主機。
- 為防止主機傾倒，請勿放置於地毯、椅墊、踏墊類、軟質地板、表面凹凸不平或波浪狀的地板、傾斜的地面、地板以外的其他地點等場所。

操作方法 1

操作流程



開始

每次按下時，將在「強力模式」⇔「標準模式」之間進行切換。
 強力模式：希望以最大吸力清掃時
 標準模式：希望降低吸力清掃時（吸住踏墊或小型地毯等物品時）

結束

清掃完成 → 電池充電 (CN-7)

● 基於衛生考量，建議每次清掃時皆清空垃圾。(CN-13、14)

重要須知

- 開始清掃後，吸頭上的旋轉刷將自動開始旋轉。
- 即使於標準模式下結束清掃，下次按下 (HIGH STD) 時，仍會以強力模式開始運作。
- 電池剩餘電力於運作期間耗盡時，將自動停止，以避免因過度放電造成電池劣化。不論使用時間長短，清掃完畢後請務必對電池充電。
- 清潔踏墊和小型地毯等時可能有異物進入吸頭導致旋轉刷停止。這種情況下，請使用標準模式清潔。

安全停止

清掃期間將吸頭（反面的安全滾輪開關 (CN-17)）抬離地板時，旋轉刷將自動暫停以確保安全。此時運作動作不會停止。
 將吸頭貼在地板上移動後，即會繼續旋轉。

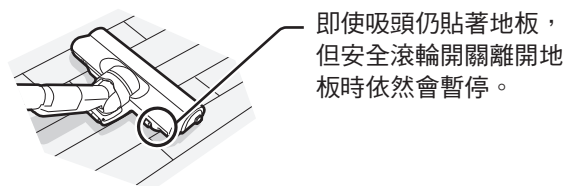

注意！

- 暫停期間請勿觸碰旋轉刷或安全滾輪開關。
 【否則將造成旋轉刷開始運作，引發受傷事故。】
 保養吸頭時，請務必先按下 OFF 停止運作後，再開始保養。

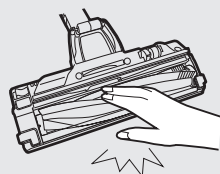

Parts that may be washed with water

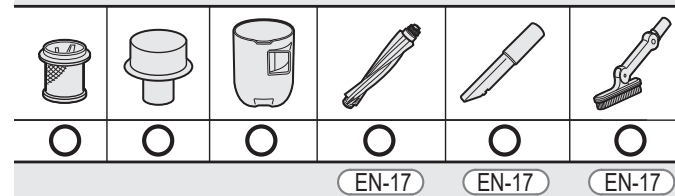

Cleaning the Filters

Pleat Filter

Dislodge and remove dirt and dust by dusting.

Dust in the direction illustrated in the diagram on the right as dirt tends to accumulate on the back side.

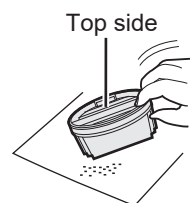

- Do not use a cleaning brush [Risk of damages].

Mesh filters (Upper and Lower), Filter Cover

Remove dirt and dust with a cleaning brush.

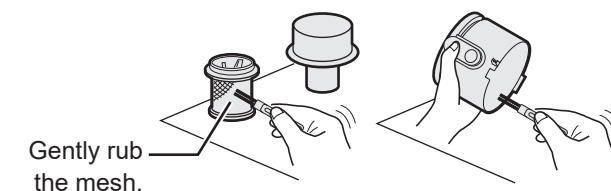

When heavily dirtied, wash with water.

Pleat filter (blue)



Carefully wash the back side.

- When the odor stands out, dilute bleach for clothing in water and immerse the filter in this solution following instruction for the bleach, then rinse with water.

Wash with water or thinned neutral detergent.

Filter Cover

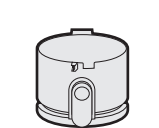

Mesh filter

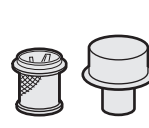

Dust Cup

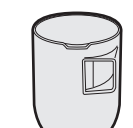

Dry the parts after washing with water.

- Thoroughly dry prior to assembling. [Risk of filter clogging not improving even after cleaning.]
 - Properly remove moisture, gently wipe off moisture with a towel or the like, dry in shade at a well ventilated location to thoroughly dry. [Risk of emission of odor or product malfunction.]
- Estimated drying time: 12 hours. (This may vary depending on the environment and season.)
- Do not apply any hot air, such as air blown by a hair dryer. [Risk of deformation or product malfunction.]

Warning

- Always do followings during maintenance
- Press the OFF to stop the operation of the product and remove the battery.
 - Disconnect the power cord of the charger from the electrical outlet.
- [Risk of electrocution or injury.]

Assembling the Filters

1 Install the Filter Cover and the Mesh filters (Upper and Lower).

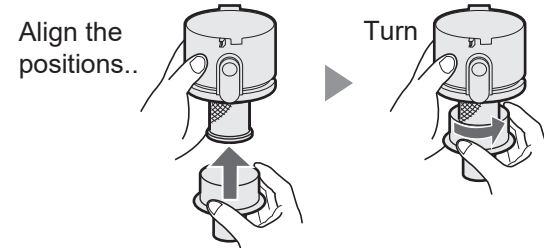
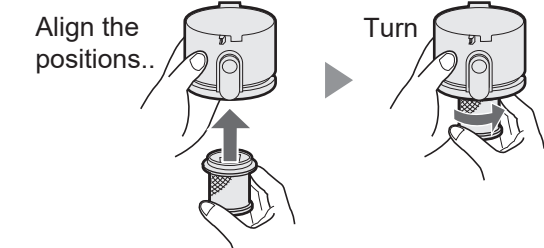

2 Align the salient part of the Pleat filter to the recessed section of the Filter Cover and press in.

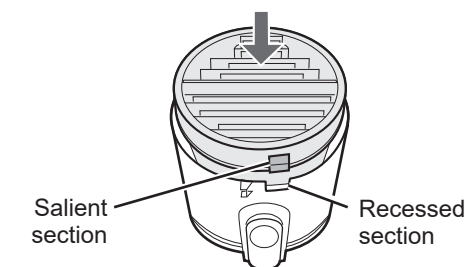

● Install the Dust Cup.

3 Install the Dust Cup.

Align the protrusion on the Dust Cup and the Dust disposal hook (yellow) and insert.

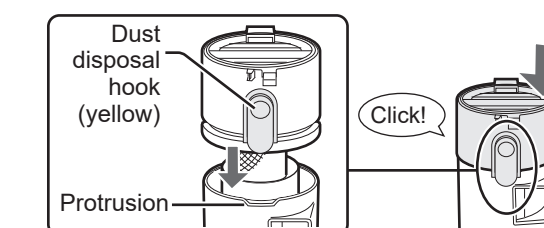

CAUTION

- Each part must be assembled correctly in order for them to fit onto the vacuum cleaner body.
- Caution is required to ensure that the Mesh filters (Upper and Lower) are not lost while throwing out dirt or cleaning.

MAINTENANCE

Suction head, vacuum cleaner body,
Enclosed nozzles and contacts
(terminals) of charging section

Suction head (Rotary brush) When lint, rubber band, hair or pet hair and the like is attached.

Removing the dirt

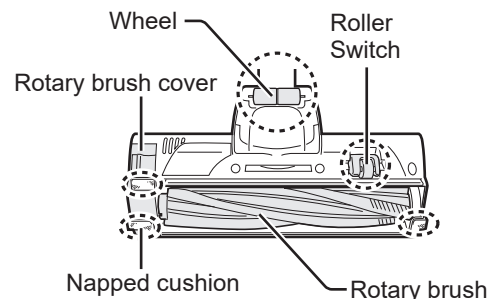

Remove the dust attached to the Suction head with a Duster Nozzle and cut off the hair and lint entangled in the section and then wipe with wrung cloth.

Remove dirt that became attached to fine parts with a pair of scissor or a pair of tweezers with thin tips.

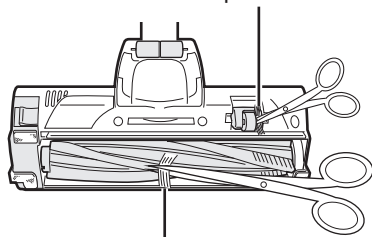

Cut along the slot of the Rotary brush for removal.
(Do not cut the tips of the bristles of the brush.)

Stop using the product when the section becomes worn, check EN-4 and contact your nearest service center approved by SHARP.

Wash with water When heavily dirtied

After removing the Rotary brush and washing it with water, remove water and moisture properly and sufficiently dry in a ventilated location before re-installing.

The Suction head cannot be washed with water in its entirety.

Removal

- Remove the Rotary brush cover by sliding the Release lever to the "OPEN" position.

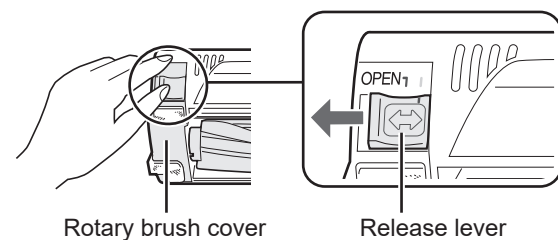

- Remove the belt from the gear while lifting up the Rotary brush and remove the Rotary brush.

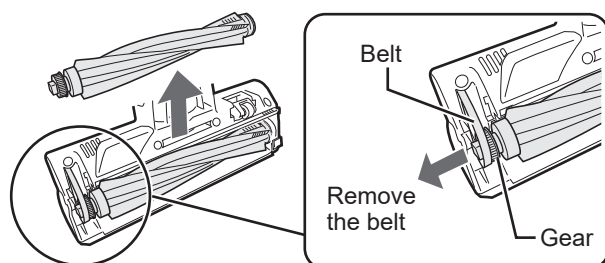

Vacuum cleaner body, Enclosed nozzles and contacts (terminals) of charging section

When heavily dirtied

Vacuum cleaner body

Wipe with cloth moistened with some water or thinned neutral detergent. Do not use any paint thinner or benzene product. [Risk of deterioration or discoloration]

CAUTION The vacuum cleaner body, charger and battery cannot be washed with water.

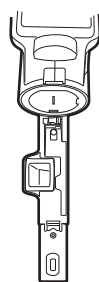

Enclosed nozzles

Wash with water or thinned neutral detergent.

Dry the parts after washing with water. EN-16

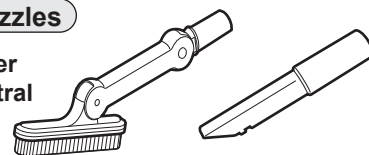

將電池插入主機

- 將電池由充電器中抽出。
- 將電池插入主機。

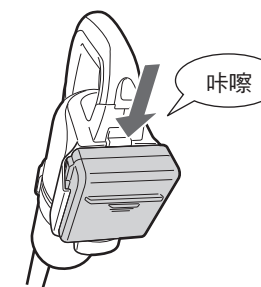
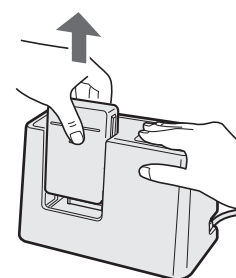

請沿著主機的凹槽，確實插入至聽見「咔嚓」聲為止。

●端子接觸後，主機的電池指示燈將亮燈約5秒鐘，顯示電池的剩餘電力。即使在尚未完全插入的狀態下指示燈即已亮燈，仍請務必完全插入至聽見「咔嚓」聲為止。

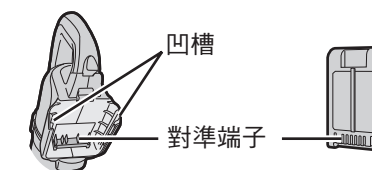

重要須知

無法充電時，請確認以下事項。

- 充電器的電源插頭是否鬆脫？
- 充電器與電池的端子有無污垢或異物附著？請以乾布擦拭乾淨。(CN-17、18)
- 電池是否正確安裝在充電器上？

開始使用電池時

- 請於電池上填寫開始使用日期。(以便在修理等情況下作為參考)



關於充電

- 以下情況可能會導致充電時間變長。
 - 長時間未使用時
 - 於低溫(約5°C以下)或高溫(約35°C以上)的環境中充電時(請於室溫為5°C~35°C的環境中充電。)

關於運作時間

- 電池會因反覆使用而使運作時間逐漸縮短。

最長連續運作時間※

強力模式	約 8 分鐘
標準模式	約 30 分鐘

※使用 1 個電池的情況(完全充滿電、電池使用初期/20°C)。會因地板材質、使用環境、使用狀態而改變。

- 電池剩餘電力耗盡時，主機的電池剩餘電力指示燈(綠色)將以持續閃爍的方式通知使用者。(CN-6)

充電器的充電中指示燈(紅色)緩慢閃爍時

- 在室溫為5°C~35°C的環境中閃爍時，代表電池已屆更換時期。(CN-4)
- 在低溫(約5°C以下)或高溫(約35°C以上)的環境中閃爍時，屬於正常現象，並非故障。請於5°C~35°C的環境中充電。(充電器的充電中指示燈(紅色)快速閃爍時，可能是充電器故障，或是電池劣化及故障。)請洽詢客戶服務中心。

準備

為延長電池的使用壽命，請參閱 (CN-6)

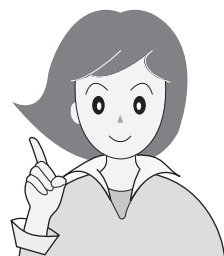

Warning

Always do the following during maintenance:

- Press the **OFF** to stop the operation of the product and remove the battery.
- Disconnect the power cord of the Charger from the electrical outlet.

[Risk of electrocution or injury.]

電池充電

剛購入時的電池尚未充分充電，使用前請務必先將電池由主機上拆下，並充電至充電器的充電指示燈（紅色）熄滅為止。

1

將電池由主機上拆下。

- ① 在將電池拆卸鍵朝箭頭方向按住不放的狀態下，
- ② 將電池朝箭頭方向拆下。

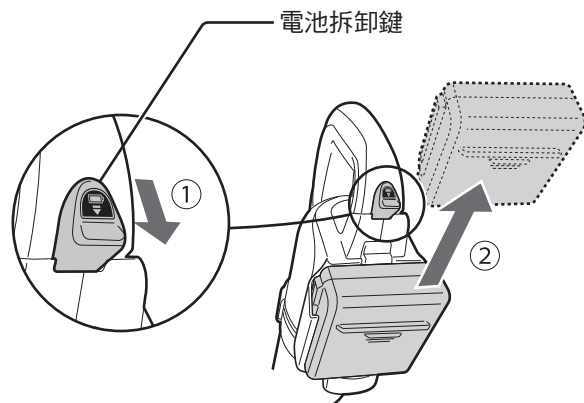

2

將充電器的電源插頭插入插座。
(插頭圖樣並不代表該國家所使用的插頭)

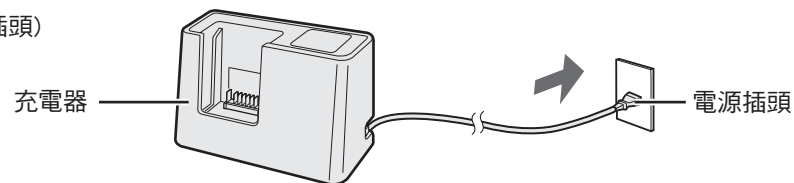

3

將電池裝到充電器上進行充電。

請確認充電指示燈（紅色）是否已亮燈。

- 持續閃爍時（以約 1 秒的間隔反覆「閃爍」），代表未確實插到底。請重新將電池插到底。

充電指示燈（紅色）的亮燈方式	充電狀態	自開始充電起算的參考時間 ※
亮燈	充電中	—
熄滅	充電完成（完全充滿）	約 80 分鐘

※ 參考時間會因充電開始時的電池剩餘電量而改變。

重要須知

• 充電中的充電器與電池溫度將會上升，此為正常現象，並非異常。

注意！

• 充電中與剛充完電時，充電器與電池的端子會處於高溫狀態，請勿觸碰。【否則可能造成灼傷】

CAUTION

- Do not use any detergent, paint thinner, benzene product or hot water (exceeding approx. 40°C). [Risk of deterioration or deformation]
- Do not apply any hot air, such as air blown by a hair dryer. [Risk of deformation or product malfunction]

Attach

- ① Insert the side without a gear of the Rotary brush, as far as it goes into the slot.

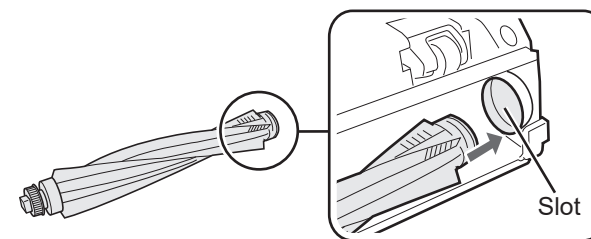

- ③ Clip on the tab on the Rotary brush cover in the slot.

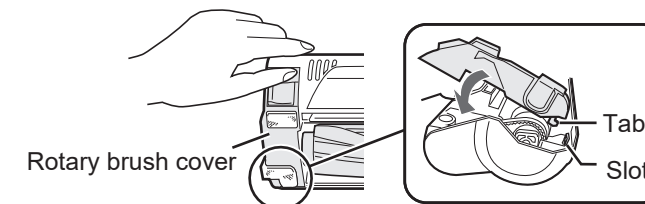

- ② Strap the belt on the gear of the Rotary brush and insert it into the slot.

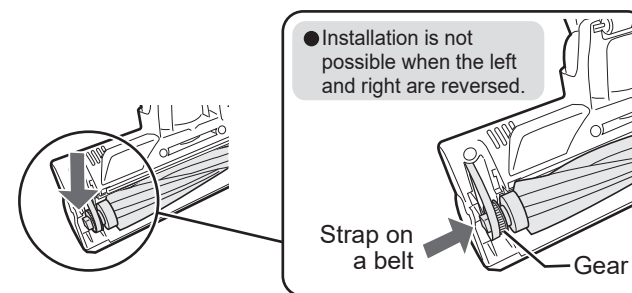

- ④ Slide the Release lever in the direction of the arrow.

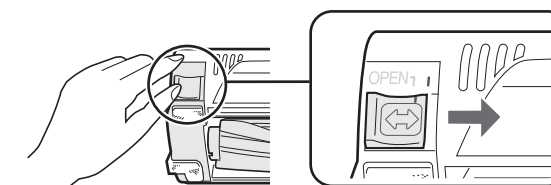

Contacts (terminals) of charging section

Wipe off any dirt with a dry cloth.

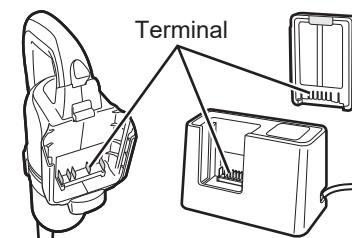

STORAGE

Storing Product

CAUTION

- Verify that there is nothing in the vicinity of the product that can be damaged easily. Pay particular attention to ensure no infant or pet is allowed to get near the product.
- If the product cannot be easily secured by hooking due to slippery floor or furniture, do not force the product to hook at a location but disassemble the product for storage instead.
- Care must be taken as the holder section may slide and leave pigment on the contacted surface, depending on the type of the wall or furniture.
- Care is needed when leaving the product standing leaning against a wall, as the product may fall.

- Store the product by hooking the holder section on furniture or the like, in a gap between a furniture and the wall, in the corner of the room or inside a closet where the product is unlikely to fall.

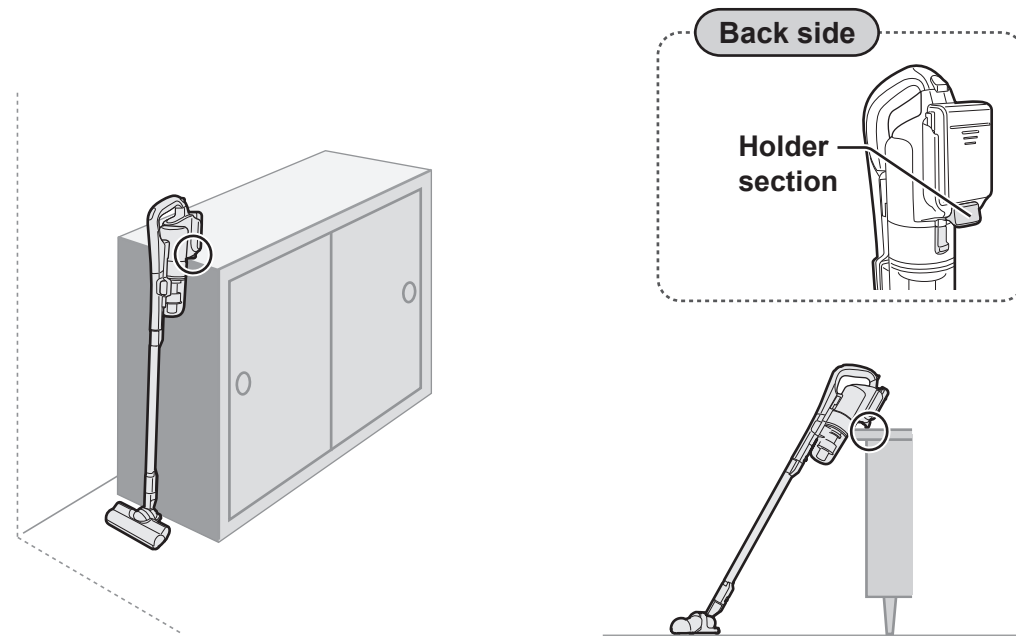

- Store the product in the condition described in the diagram below when not using the product for a long period of time.

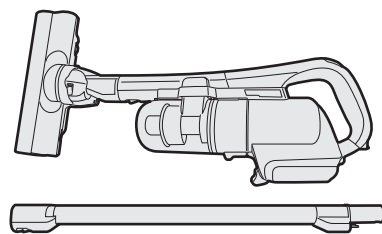

以手提狀態使用時

要拆下各零件時，請以同時按住「裝卸按鍵」的方式拆下。

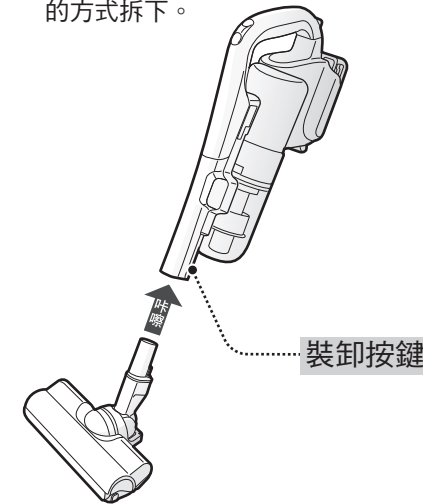

延長電池使用壽命 的要訣

不論使用時間長短，清掃完畢後請務必充電。

- 在電池剩餘電力尚未完全耗盡前即充電的做法，較能延長電池的使用壽命。
 - 直接在電池電力完全耗盡的狀態下放置時，將造成電池劣化。
- 長期間不使用時的須知 (CN-4)

電池的更換基準

充放電約 1,100 次*

- ◆ 依據反覆充放電的本公司基準進行試驗的情況。電池的使用壽命會因使用條件與環境而改變。

主機指示燈的亮燈方式

透過指示燈告知使用者主機的狀況



指示燈的亮燈方式	異常狀況／通知內容
清理濾網燈 (紅色) 	亮燈 ^{※2} 請清理垃圾，並去除濾網上的污垢與灰塵。(CN-13、14) 集塵筒組的濾網過髒。
	快速閃爍 請用水清洗濾網。 集塵筒組的濾網阻塞。(CN-15、16) 主機過熱。 請於陰涼處放置片刻。 若繼續讓吸塵機運作，未將其冷卻，將觸發主機的過熱保護功能，導致吸塵機暫時無法使用。
電池剩餘電力指示燈 (綠色) 	亮燈 電池剩餘電力充足。
	閃爍 電池剩餘電力過低。
	快速閃爍 電池剩餘電力即將耗盡。 (電池剩餘電力已耗盡。) 敬請充電。(CN-7)

※1 電池剩餘電力指示燈的亮燈時機如下。(電池剩餘電力完全耗盡時，不會亮燈。)

- 自電池安裝至主機上的時間點起算約 5 秒鐘
- 清掃期間
- 自按下 OFF 停止運作的時間點起算約 5 秒鐘

※2 吸頭被堵住時，即使濾網不髒，亦可能會亮燈。如遇此情況，請先按下 OFF 後，再讓吸塵機運作，指示燈即會熄滅。(停止約 10 秒後燈光將熄滅)

各部份名稱

各部份名稱與組裝方法

以直立狀態使用時

- 要拆下各零件時，請以同時按住「裝卸按鍵」的方式拆下。

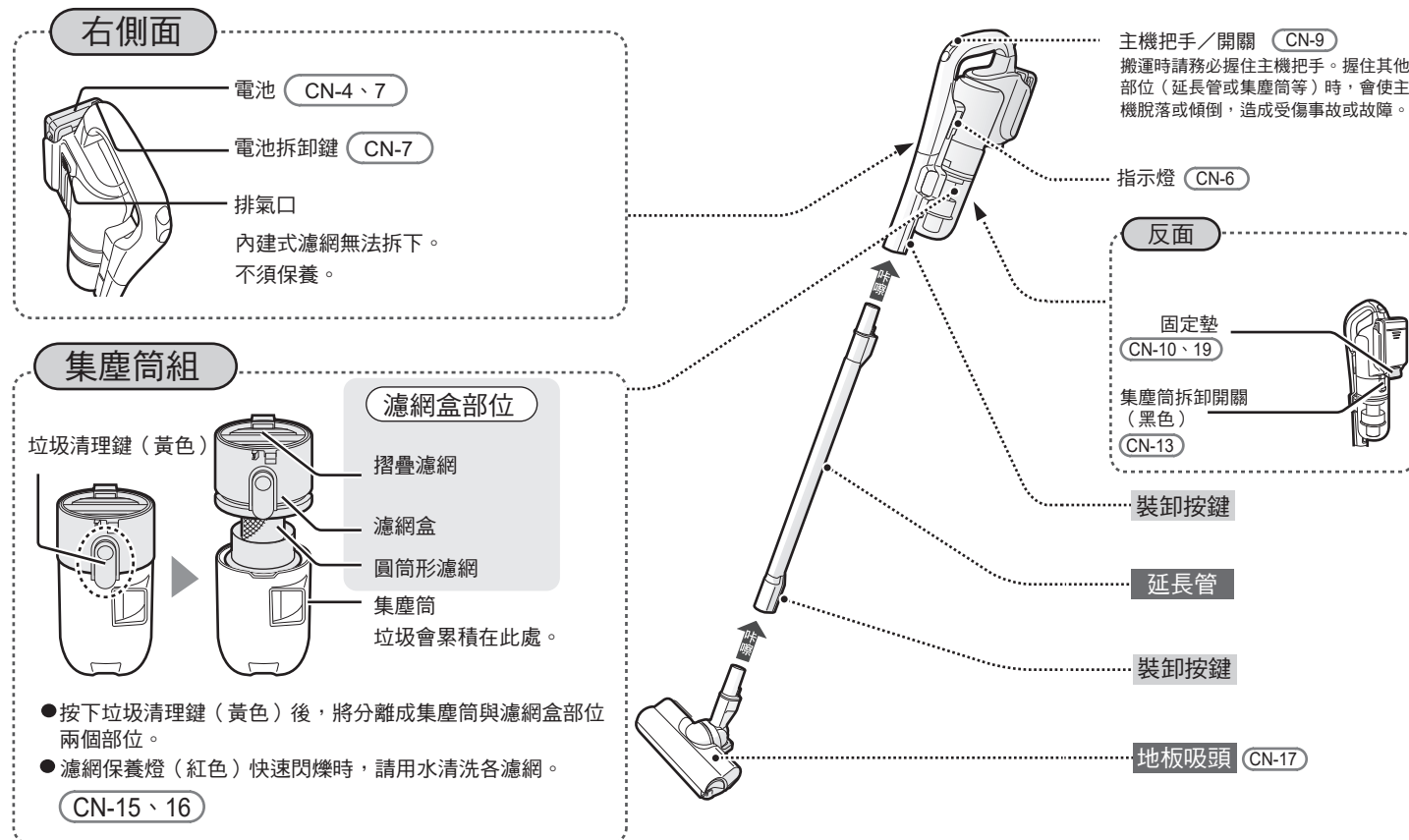

附屬配件

上述的「地板吸頭」與「延長管」亦屬於附屬配件。

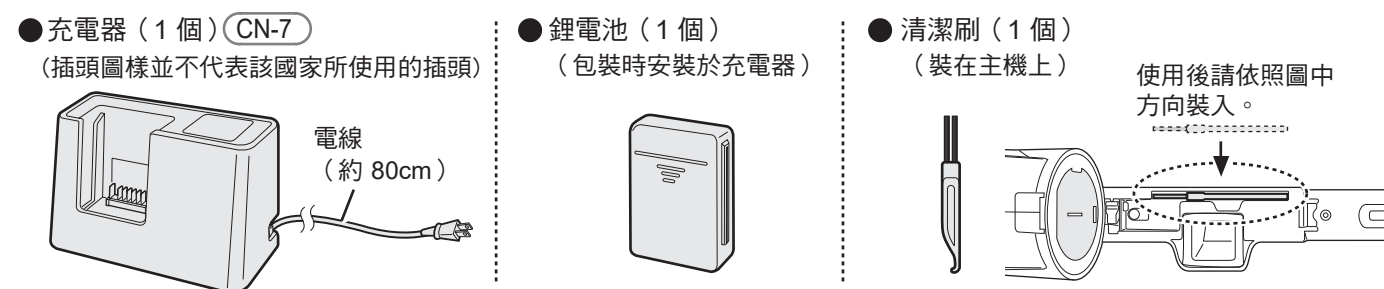

附屬吸頭 (CN-11、12)

- 除塵毛刷吸頭 (1個)
- 狹縫吸頭 (1個)



CN-5

SPECIFICATIONS

Power supply	Input 100 - 240 V ~ 50-60 Hz (charger)
Power supply method	Rechargeable type (lithium ion battery, 18V $\overleftrightarrow{=}$)
Electric power consumption	While charging: Approx. 40 W; After charging: Approx. 0.5 W
Continuous operation time*	High mode: Approx. 8 minutes Standard mode: Approx. 30 minutes
Dust collecting capacity	0.13 L
Charging time	Approx. 80 minutes (charging may take up to maximum of about 2 hours depending on the conditions of use, such as the surrounding temperature or duration of use)
Weight	1.5 kg (Suction head, pipe, base unit and battery included) 0.6 kg (charger)
Base unit dimensions	222 mm W x 220 mm D x 980 mm H
charger dimensions	200 mm W x 90 mm D x 133 mm H
Cord length	80 cm (charger)

※ When a single battery is used (fully charged and initial condition of the battery / 20°C).
Conditions may vary depending on the material of the floor surface, environment in which the product is used and the condition under which the product is used.

INSTRUCTION MANUAL FOR BATTERY PACK (BY-5SB)

“ Disposal method and Storage method ”

Dispose of used batteries according to local ordinances and/or regulations. After extended periods of storage, it may be necessary to charge and discharge the cells or batteries several times to obtain maximum performance. Do not store cells or batteries haphazardly in a box or drawer where they may short-circuit each other or be short-circuited by other metal objects. Keep cells and batteries clean and dry. Replace only with same SHARP Corporation type BY-5SB battery pack.

“ Charging Information ”

Nominal Specifications		
Item	Specifications	Remark
Charging Current (Std.)	1.95A	0~10°C
	3.90A	10~60°C
Charging Voltage (Std.)	20.75V	0~45°C
	20.25V	45~60°C
Charging cut current	100mA	0~60°C

Charge Limits		
Battery Pack Model	Maximum Charge Current, A	Maximum Charge Voltage, V
BY-5SB	3.9A(0~10°C)	20.87V
	7.8A(10~60°C)	

EN-20

TROUBLESHOOTING

重要須知

Symptoms	Check here	Reference Pages	
Problems with vacuum cleaner body during operation	The product does not operate (Movements are strange)	<ul style="list-style-type: none"> Is the charge remaining in the battery low? Charge the battery. Is the battery correctly set to the vacuum cleaner body? Remove the battery from the vacuum cleaner body, wait for about one minutes to pass and then reinstall the battery on the vacuum cleaner body and restart the operation.(The vacuum cleaner body circuit becomes reset and the product is restored to normal operation.) 	EN-7 EN-8 —
	OFF was pressed but the operation does not stop immediately.	<ul style="list-style-type: none"> The motor keeps on turning for a while even after the OFF is pressed, but this is not a malfunction. 	—
	Operation time is shorter.	<ul style="list-style-type: none"> The operating time gradually becomes shorter as the battery is used repeatedly. Replace the battery when the operating time is extremely short even when the battery has been charged. 	EN-4
	Abnormal sound is emitted.	<ul style="list-style-type: none"> Is the Dust cup assembly correctly installed on the vacuum cleaner body? Is there any dirt or foreign matter trapped between the Pleat filter and the Mesh filters? 	EN-14 EN-16
	Filter care lamp (red) turns on. (EN-6)	<ul style="list-style-type: none"> Is the filter of the Dust cup assembly is dirty? Remove the Dust cup assembly, dispose of dirt and remove the dirt and dust on the filter. Is the Suction head blocked? (When cleaning a mat or a enclosed nozzle is used) Press the OFF and then restarting operation turns the lamp off. 	EN-13, 14 EN-15, 16 EN-6
	The suction power becomes weak during operation in the "High mode".	<ul style="list-style-type: none"> Continuously performing power operation at a location exposed to direct sun light or in an environment with high temperature such as inside a car parked under the flaming sun and the like can automatically reduce the suction power as the overheating protection circuit is triggered to prevent deterioration of the battery. Is there any clogging on the Mesh filters or Pleat filter? Clean the filter by rinsing with water. 	EN-1 EN-15, 16
	The product stops during operations. Filter care lamp (red) blinks rapidly. (EN-6)	<ul style="list-style-type: none"> Is the vacuum cleaner body overheating? Leave the product in a cool place for a while. Is the charge remaining in the battery low? Charge the battery. Is there any clogging on the Mesh filters or Pleat filter? Clean the filter by rinsing with water. 	EN-6 EN-7 EN-15, 16
	The suction power is weak. The operating sound changed or became louder.	<ul style="list-style-type: none"> Is there much dirt accumulating in the Dust Cup? Is there any large dirt such as a piece of tissue paper entangled inside the Dust Cup? Is there any dirt clogging the pipe or the Suction head? Remove the clogging dirt. 	EN-13, 14 EN-13, 14 —
	Contact your nearest service center approved by SHARP if the product still stops during cleaning even if the measures described above have been implemented.		
	Charging	The battery cannot be charged. (The Charging lamp (red) of the charger is not turned on)	<ul style="list-style-type: none"> Is the power plug of the charger securely inserted in the power outlet? Is the battery correctly set to the charger? Is there any dirt or foreign matter attached to a terminal of the charger or the battery? Remove the dirt or foreign matter with dry cloth.
The battery cannot be charged. (The Charging lamp (red) of the charger blinks rapidly)		<ul style="list-style-type: none"> The symptom may be caused by malfunction of the charger, deterioration or malfunction of the battery. Contact your nearest service center approved by SHARP. (Leaving a battery without charging and depleted for a prolonged period of time can deteriorate the battery, which may need to be replaced.) 	EN-6
The Charging lamp (red) of the charger blinks slowly)		<ul style="list-style-type: none"> If the slow blinking occurs when the room temperature is between 5°C and 35°C, then it is time to replace the battery. Replace the battery. There is no malfunction if the product blinks slowly in an environment with a low temperature (about 5°C or lower) or a high temperature (about 35°C or higher). Charge the battery in an environment that is between 5°C to 35°C. 	EN-4 —

亦須注意的其他事項

地板吸頭反面的安全滾輪開關、車輪、緩衝毛墊已磨損時，可能會刮傷地面。

● 部位已磨損時，必須更換為新品。請停止使用，並洽詢客戶服務中心。

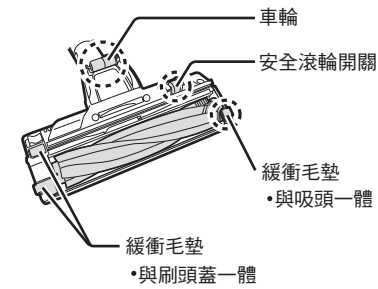

● 的零件需以送修方式修理。
● 更換用零件（皮帶保護蓋）可單獨選購。

- 吸塵機避免吸入以下物品。（否則可能造成內部受損、垃圾堵塞、或故障）
 - 液體或潮濕的垃圾。
 - 繩索類
 - 尖銳的物品（玻璃、刮鬍刀等）。
 - 大量砂礫
 - 不可讓吸塵機吸入大型垃圾，或一次吸入大量垃圾。
- 吸塵機吸入細小的粉末類（石膏、水泥、粉筆等）物質時，請保養各濾網。（CN-15、16）
- 不可在拆下集塵筒組（CN-5）的狀態下運作。
- 不可用於打掃赤腳行走的玄關處。
- 請勿將吸頭用力頂住地板與門檻的高低差部分、家具、以及牆壁等處（否則可能刮傷地面等處）。
- 請勿對旋轉刷加油（否則可能造成塑膠龜裂）。
- 請勿拖行充電器（否則可能刮傷地板等處）。

長時間不使用注意事項

● 請由主機上拆卸電池，並務必將電池完全充滿電之後，再進行保存。（CN-7）

建議拔掉充電器電源插頭。維持在插入電源插頭狀態時，將耗用約 0.5W 的電力。不需使用時請拔掉電源插頭，可避免耗電。

- 收納電池時，請注意以下事項。請勿與鐵絲、項鍊、耳環等金屬類一同搬運及收納。請保存於濕氣和灰塵較小的地方。（否則可能造成發熱、起火燃燒、觸電）
- 經長時間存放後，可能需對電池充電、放電數次以達到其最大效能。

- 運作期間可能會造成電視機畫面出現雜訊，但不會對電視機造成影響。
- 本充電式吸塵機為家庭用，請不要當作商用吸塵機使用。此外，請不要使用在吸地以外的用途上。

更換電池

電池屬於消耗品，會因反覆使用而導致運作時間逐漸縮短。雖然電池的劣化速度會因使用狀況與工作環境而改變，但只要出現以下任一情況時，即請更換電池。

● 電池的更換基準 (CN-6)

- 即使已完全充滿電，仍只能運作極短時間。
- 每次在室溫 5°C~35°C 的環境中充電時，充電器的充電指示燈（紅色）皆緩慢閃爍時。

（在低溫（約 5°C 以下）或高溫（約 35°C 以上）的環境中充電，充電器的充電指示燈（紅色）緩慢閃爍時，屬於正常現象，絕非故障。請於 5°C~35°C 的環境中充電。）

請協助回收電池。

電池（鋰離子電池）為可回收使用的珍貴資源。不需再使用的電池請勿丟棄，並送至提供充電式電池回收服務的店家。

不再使用之電池的處理方式

請以市售的絕緣膠帶等物品將端子部位絕緣，並請勿將其分解。

請根據當地政府制定的規則進行處理。

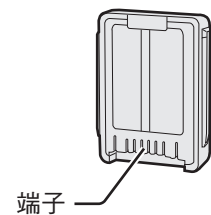

安全注意事項 2

關於電池



危險

防止觸電或火災等事故與重傷事故



- 電池不可使用於本公司吸塵機以外的其他機器上，且不可自行將電池分解、改造或單獨充電。（否則可能造成火災、觸電、受傷事故）
- 不可使用本產品隨附的充電器以外的充電器。
- 電池不可短路，請勿以鐵絲或針等金屬類接觸端子，或是與項鍊或耳環等物品一同搬運及保管。
- 請勿釘入釘子、用鐵鎚敲打、用力踩踏等造成強大衝擊的行為並且請勿丟擲。
- 電池因掉落等因素而變形或受損時，請勿繼續使用。
- 不可投入火中或進行加熱。
- 不可放置於火源或暖爐旁、受到陽光直接照射處、以及酷熱天氣下的車內等高溫處。
- 不可泡水或淋濕。
- 充電器請勿用非本公司指定的電池進行充電。
（否則可能出現發熱、冒煙、破裂、起火燃燒、電池液外漏）



- 請務必使用本公司指定的電池。
（否則可能出現發熱、冒煙、破裂、起火燃燒）
- 電池內部的液體外漏並誤入眼睛時，請勿搓揉眼睛，並立即以自來水等清水充分沖洗眼睛後，盡快就醫。
（否則可能造成眼睛受損）



警告

防止觸電、火災、漏電、重大傷害



- 察覺電池出現異臭、發熱、液體外漏、變色、變形等未曾出現過的異常情況，請勿繼續使用。
（否則可能出現發熱、冒煙、破裂、起火燃燒）
- 請勿以濕手觸碰電池。
（否則可能造成發熱、起火燃燒、觸電）



- 電池內部的液體外漏，接觸皮膚或衣物上時，請立即以自來水等清水充分沖洗。
（否則可能造成皮膚受損）
- 電池請放置於嬰幼兒無法取得之處。
- 超過規定的充電時間仍無法完全充滿電時，請停止充電並更換電池。 **CN-4**
- 當電池的端子不潔時，以清潔的乾布擦拭。



注意

防止觸電、火災、主機故障、傷害事故



- 充電請務必在5°C~35°C的環境中進行。
（否則可能出現發熱、冒煙、破裂、起火燃燒的情況，或是無法正常充電與電池劣化的情況。）
- 請於濕氣和灰塵較小的地方使用與保存。
（否則可能造成發熱、起火燃燒、觸電）

Check details described below (prior to requesting for repairs or contacting for inquiries).



Symptoms	Check here	Reference Pages	
Hot	The temperature of the vacuum cleaner body can rise to about 40°C during operation, but this is not abnormal.		
	The vacuum cleaner body is hot	● Is there any clogging on the Mesh filters or Pleat filter?	EN-15, 16
Dust cup assembly	The charger or the battery becomes hot while charging.	● Heat is generated due to the electrical current that is supplied to the control circuit, but this is not abnormal.	—
	The Dust cup assembly cannot be installed on the vacuum cleaner body	● Are respective components of the Dust cup assembly assembled properly?	EN-16
Suction head & Rotary brush	The Dust cup assembly cannot be assembled.	● Is there any dirt accumulating at the bottom of the Dust Cup? ● Is there any dirt entangled on the Mesh filters? ● Is the Pleat filter properly installed to the Filter Cover? ● Are respective components of the Dust cup assembly assembled properly?	EN-14 EN-16 EN-16 EN-16
	The Rotary brush does not rotate.	● The Rotary brush stops automatically for safety purpose when the Suction head is off the floor. (Safety Stop) ● Is the pipe dislodged from the vacuum cleaner body? ● Is any hair or lint tangled on the brush? ● The Rotary brush may stop in some instances as the automatic stop function is triggered when the Suction head becomes stuck on a surface when the product is used to clean carpets and mats on which the Suction head can become closely attached and blocked. In such instances, turn off the product. The automatic stop function will be released and the product can then be used again. ● Is the Suction head assembled properly? ● During the cleaning of mats or rugs, the Suction head may get stuck to the material and the Rotary brush may stop. In this case, continue cleaning in Standard mode.	EN-9 — EN-17 — EN-17 EN-9
Odor	A rattling sound is coming out of the Suction head.	● This is a sound emitted by the Roller Switch, due to the structure (safety stop mechanism). This is not abnormal.	—
	The air discharged from the vacuum cleaner body smells.	● Is there much dirt accumulating in the Dust Cup? (Depending on the type of accumulated dirt some odor may be emitted.) ● Has the Mesh filters or the Pleat filter been washed with water and then sufficiently dried? [Using the product while moisture remains on or in the product may lead to the emission of an odor]	EN-13, 14 EN-15, 16
Others	A part of the Pleat filter appears to be white and floating.	● The white filter material can become visible at times, but there is no quality issue with such a situation.	—

If the Filter care lamp (red) and the Battery level indicator lamp (green) on the vacuum cleaner body are blinking simultaneously the product may be malfunctioning. Contact your nearest service center approved by SHARP.

安全注意事項 1

為避免危害人體與造成財產損失，以下將說明必須遵守的事項。

■ 本書將使用方式不當所引發的內容，分為以下類別進行說明。



危險 「極可能造成死亡或重傷」的內容。



警告 「可能會造成死亡或重傷」的內容。



注意 「可能會造成輕傷或財物受損」的內容。

■ 本書使用以下圖示說明須遵守之內容的種類。



不能做的事。



必須遵守的事。



警告

防止觸電、火災、漏電、重大傷害



注意

防止觸電、火災、主機故障、傷害事故

充電器



- 請勿使用於分接插座。
(否則可能造成火災、觸電。)
- 請避免造成電源插頭與電源線破損。
 - 請勿過度彎曲、拉扯、扭轉、纏綁，並避免遭到其他物品夾住，且不可自行加工。
 - 避免捲入吸頭的旋轉刷頭內。
 - 避免造成損傷或於上方放置重物(否則可能導致電線受損，引發火災與觸電事故。)

- 請勿使用已鬆弛的電源插座。
- 請勿以濕的手插拔電源插頭。
- 電源插頭或電源線已受損時，請勿使用。
(否則可能造成觸電、短路、起火燃燒、受傷事故。)



- 請務必使用本產品所附的充電器。
請勿使用延長線。
(否則可能造成火災、觸電、故障。)
- 請定期清理電源插頭上的灰塵：拔出插頭，以乾布擦拭乾淨。
(若插頭上累積過多灰塵，恐因濕氣等因素而造成絕緣不良，並引發火災。)
- 電源插頭請確實整個插入插座。
(若未完全插入的話，可能會造成火災、觸電、短路。)

出現異常或故障時，請立即停止使用。



- 常出現開啟開關時無法運作的情況。
- 充電中移動充電器的電源插頭或電源線時，充電指示燈出現亮燈或熄滅的情況。
- 運作期間發出異常聲響。
- 主機與充電器變形或異常過熱。
- 發出焦臭味。

- 主機需立即按下 **OFF**，拆下電池。
- 充電器須立即將電源插頭由插座上拔出。

請先確認「故障排除」(CN-21、22) 後，再與客戶服務中心聯繫。

使用地點與使用時



- 請勿在可燃性的物體旁邊使用，或是使吸塵機吸入該物體。
 - 煤油、汽油、線香
 - 揮發油、稀釋劑
 - 菸蒂
 - 碳粉等可燃物等
(否則可能引起爆炸與火災)

- 切勿在浴室等潮濕的地點、可能會被淋濕的地點、高溫多濕的地點使用，或是使吸塵機吸入水分。
(否則可能造成觸電、短路、起火燃燒)

- 請勿對主機與充電器潑水或潑灑清潔劑，或是用水清洗(可水洗的零件除外)。
(否則可能造成觸電、短路、起火燃燒)

- 不得投入火中或進行加熱。
此外請勿放置於火源或暖爐旁、受到陽光直接照射的地方、以及酷熱天氣下的車內等高溫處。
(否則可能引發短路、起火燃燒、電池液外漏、爆炸等事故。)

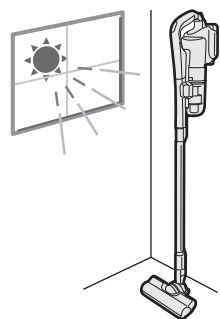

使用時請遵守以下事項。



- 不可自行改造主機與充電器，並且不得由非專業維修人員進行分解或修理。
(否則可能造成火災、觸電、受傷事故)
如需修理時，請洽詢客戶服務中心。

- 充電期間或剛充電時，不得觸碰充電器與電池的端子。**(CN-7)**
(否則可能造成灼傷)

- 不得以鐵絲或針等的金屬物品，觸碰主機、充電器、電池的端子。
(否則可能造成發熱、起火燃燒、故障)

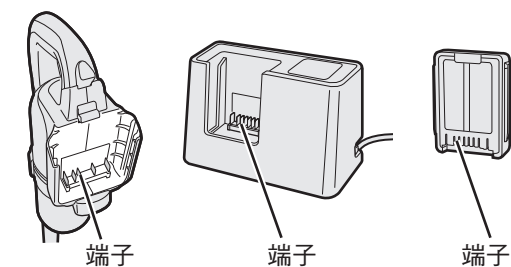

- 不得觸碰旋轉刷與安全滾輪開關(安全停止裝置)。
(否則可能造成手部等部位受傷)
請特別注意兒童。

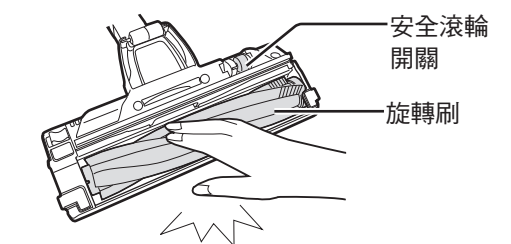

- 保養與檢查時務必遵守以下事項。
 - 主機需按下 **OFF**，拆下電池。
 - 充電器需將電源插頭拔出。
(否則可能造成觸電或受傷事故)

使用時請遵守以下事項。



- 不要堵住排氣口。
- 不要以堵住吸頭的狀態長時間運作。
(否則可能因過熱造成主機變形、起火燃燒、引發火災)



- 不要將金屬類或針等物品放入延長管插入口、延長管接點、排氣口。
(否則可能造成觸電或故障)

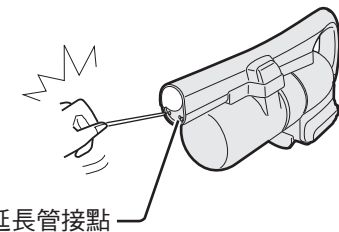

- 不要以握住延長管或集塵筒的方式搬運主機。
(否則可能導致主機脫落或倒下，造成受傷事故或故障。)

充電器請遵守以下事項。



- 拔插頭時，一定要抓著插頭拔。
(否則可能造成觸電、短路、起火燃燒)
- 長期間不使用時，一定要拔掉插頭。
(否則可能因絕緣劣化導致觸電、漏電、火災)