

# SHARP

Cordless Vacuum Cleaner

EC-SC85H-H

## Operation Manual

Read this operation manual carefully before first use. Keep this manual for further guidance in case.



# Introduction

---

**SHARP**

Thank you for buying Sharp brand household cleaning electrical appliances, and wish you a pleasant use!

Please read this instruction carefully to know how to operate this product safely and correctly, and obtain the most ideal use effect from it.

This instruction includes the latest information as of the time of printing, and the Sharp Corporation. is solely responsible for the revision, interpretation and explanation of this manual. The Company's strategy is to continuously modify the products, so the Company reserves the right to change the products without notice after this instruction is printed.

In the process of using, if you have any questions and suggestions about our products, please call our service centre. We will serve you wholeheartedly!

# Contents

SHARP

Safety Operation Guide .....	EN-1
Introduction of Product Components .....	EN-3
Operation Method .....	EN-4
Troubleshooting .....	EN-7
Specifications .....	EN-7

# Safety Operation Guide

SHARP

**Note:** Please read and understand the instructions before use, and keep it for later reference.



Please do not use the product outdoors in rainy days

Warnings: In the use of any household appliances, safety precautions shall be taken, including but not limited to the prevention of fire, short circuit and personal injury.

## Personal safety:

1. Please store the machine in a dry area indoors and stay it away from children;
2. Children over 10 years old and people with physical and mental disabilities must use it under the supervision of their guardians;
3. Please do not let children under 10 years old contact with the machine. When using and maintaining the machine, please keep away from children under 10 years old;
4. Please use the matching accessories in the package; incorrect operation or use of other mismatched accessory may cause personal injury;
5. Please pay special attention to operational safety when cleaning the stairs;
6. Please keep the machine away from hot surfaces;
7. Please keep the air inlet unobstructed and keep away from the fluff, cloth and other things that are easy to block the machine;

## Power safety:

1. Please use the battery and charger provided in the package;
2. Please do not change the charger in any way;
3. Please make sure that the input voltage matches the voltage marked on the charger;
4. The charger and battery are matched with each other. If the charger of other specifications is used, fire risk may be caused;
5. Please check the power cord of the charger for signs of damage and aging before use. Using a damaged or wrapped charger will increase the risk of fire and short circuit;
6. Please use the power cord of the charger correctly;
7. Please do not lift the charger through the charger wire;
8. Please do not unplug the charger by pulling the charger wire. Please hold the charger with your hand for plugging;
9. Please do not store the charger by wrapping the charger wire around the charger;
10. The charger wire must be kept away from hot surfaces or sharp objects;
11. The charger wire cannot be replaced by oneself. If the charger wire is damaged, please contact the after-sale service for replacement.
12. Please do not touch the charger or the whole machine with wet hands;
13. Please do not store the machine outdoors or charge the machine outdoors;
14. When cleaning and maintaining the machine, please make sure that the charger has been removed from the charging plug.

# Safety Operation Guide

SHARP

# Introduction of Product Components SHARP

## Battery Safety:

1. The lithium battery is used in this product. Please do not burn or expose it to high temperature;
  2. Please use the original battery. Replacing the wrong type of battery may cause safety risks;
  3. The battery is forbidden to be disassembled, impacted, squeezed or put into the fire. If there is serious bulging, please do not continue to use;
  4. Please do not disassemble or collide to avoid the liquid leakage in the battery;
  5. Please do not short connect the metal contacts of the battery, or the danger of short-circuit will be caused (avoid personal injury, such as burns caused by overheating of the battery);
  6. Please handle the battery properly according to local regulations;
- ※ In order to reduce burns, fire, electric shock or any other injury, please observe the above regulations

## Services:

1. Before use, please carefully check the product for damage and abnormalities;
2. Please do not use if there is any damage or defect in the product;
3. Please contact Sharp approved service centre or a suitably qualified person and perform maintenance in accordance with relevant safety regulations. Maintenance by non-professionals may cause safety risks;
4. Please do not change this product in any way to prevent personal injury;
5. Please use replacement parts or spare parts provided or recommended by the manufacturer.

## Tips for use:

1. This is a dry vacuum cleaner;
2. This vacuum cleaner does not have waterproof function. Please do not inhale water and wet dust;
3. This vacuum cleaner cannot absorb any burning or smoking dust;
4. Please only use in accordance with the instructions in the manual;
5. Please do not use it on concrete pavement, asphalt pavement and other rough surfaces;
6. The vacuum cleaner is used for household; please do not use it in factories or commercial places;
7. Please do not use it to absorb construction waste and heavy metal dust.

## Warnings:



1. Please do not use water, solvent or polishing agent to clean the surface of the appliance; Please clean with dry cloth;
2. It is forbidden to soak the vacuum cleaner in water or use a machine to clean it.

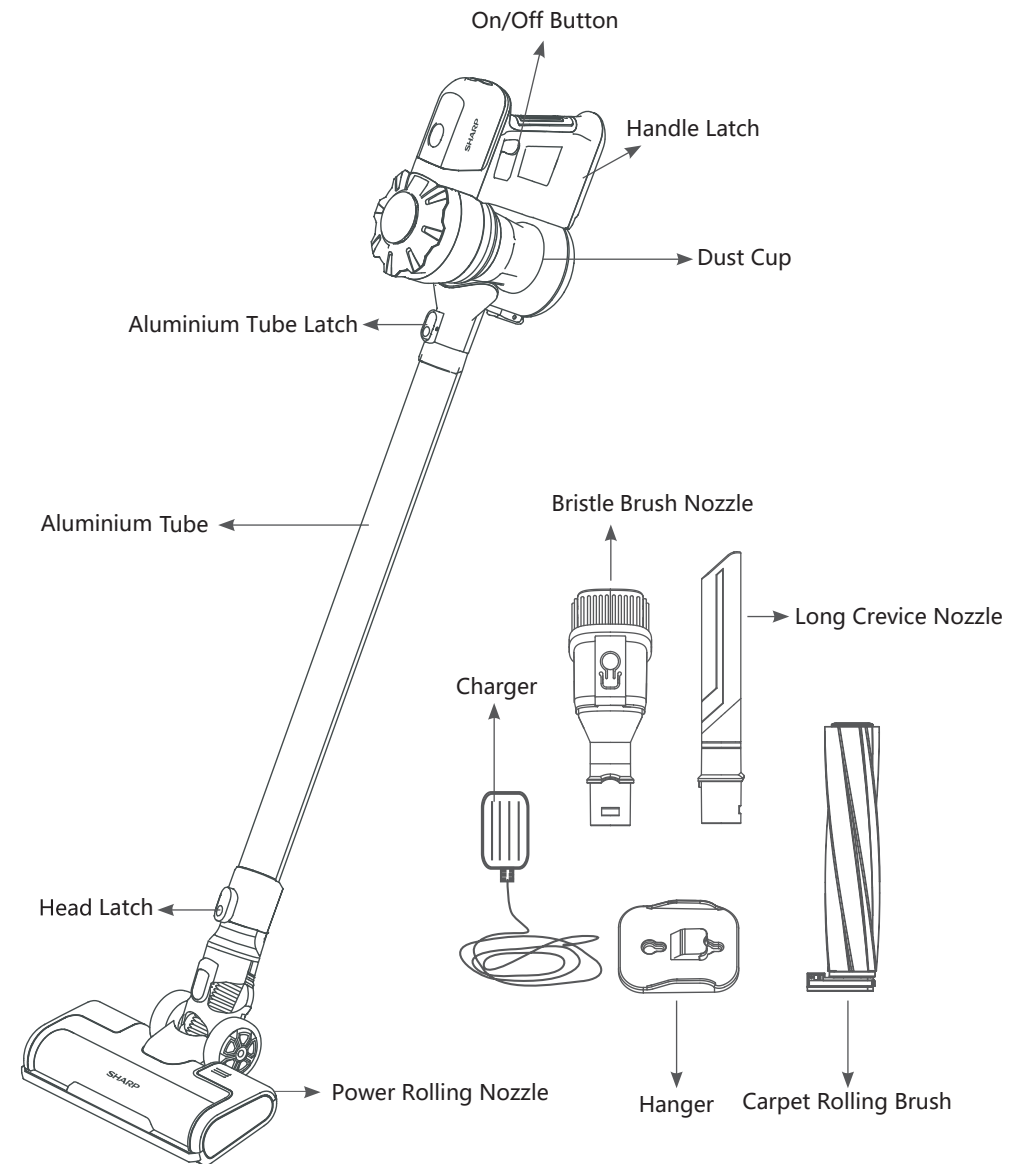

# Operation Method

SHARP

## I. Use as the stick vacuum cleaner:

1. Assemble the battery into the dust cup, make sure the battery bolt head is inserted into the dust cup slot rightly as below.

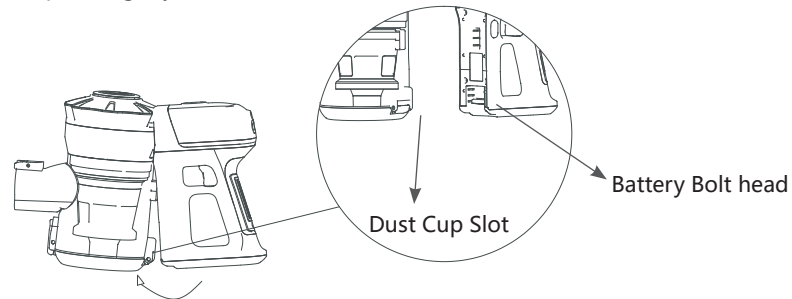

2. Attach the aluminium tube to the main part as below until hearing the click sound.

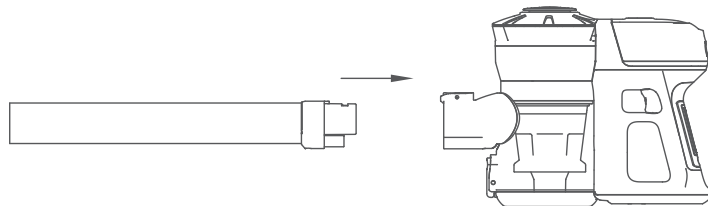

3. Attach the head to the tube as shown below.

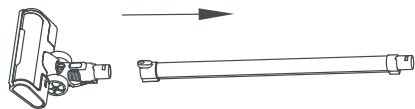

4. Press the On/Off button to start the machine.  
Two suction speeds control.

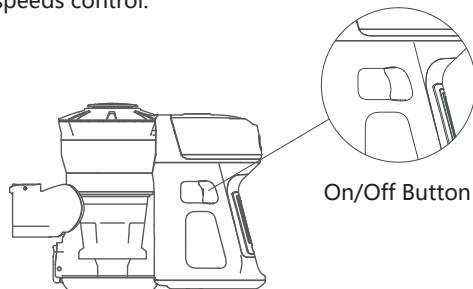

# Operation Method

SHARP

- a. Turn on the On/Off button to use the low speed mode.
- b. Press the On/Off button again to change to high speed mode.
- c. Press the On/Off button again to stop the machine.

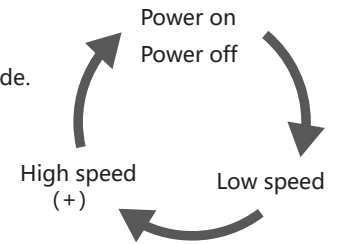

## II. How to use as a handheld vacuum:

Insert the accessory (bristle brush nozzle or long crevice nozzle) to the main part as shown below until hearing the click sound

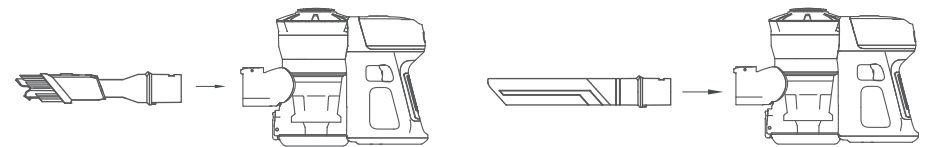

## III. How to charge:

- 1) When only one indicator light is blinking, please turn off the appliance. Hang up the machine and then plug in charger power cable into the main body for charging. When charging, the indicate lights will become flashing white.

### Note: Hanger installation method

- 1. Use expansion screws to hang the vacuum cleaner on the wall.

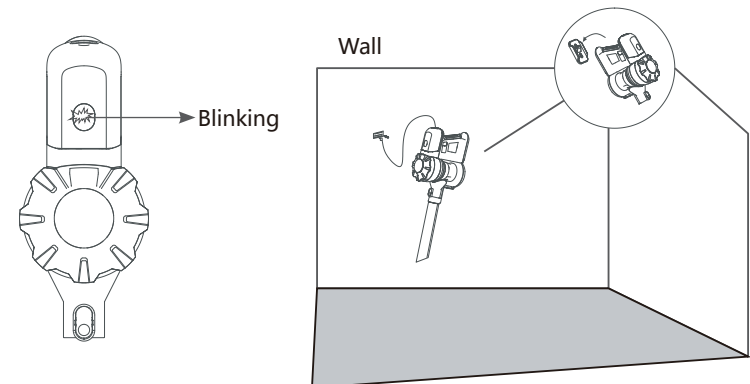

2) It will have 3 White lights on after fully charged.



## IV. Dust cup cleaning method

1) Press the handle latch to remove the battery from dust cup.

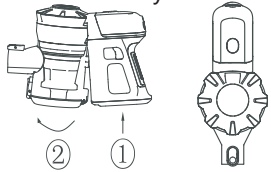

2) Separate and remove the top cover as shown below.

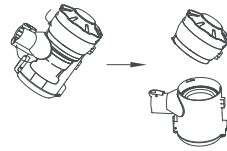

3) Take out the filter case, then take out the filter.

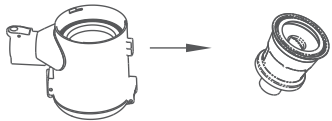

4) Wash the filter case and the filter by water.

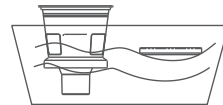

5) Please dry the filter and the filter case completely before assembling back.

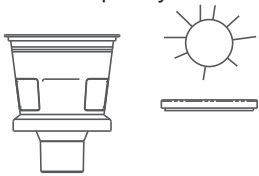

6) After drying, assemble the filter to the case.

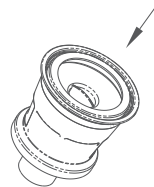

7) Put the filter case back to the dust cup.

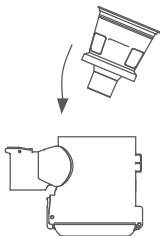

8) Assemble the top cover to the dust cup.

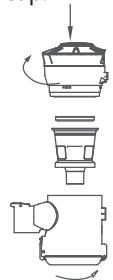

## ※Troubleshooting:

Suction gets weak	<ol style="list-style-type: none"> <li>1. Empty the dust cup</li> <li>2. Check if the dust cup is installed correctly</li> <li>3. Check if the filter case and the filter are installed correctly</li> <li>4. Clean the filter</li> </ol>
Stop working	<ol style="list-style-type: none"> <li>1. Charge the vacuum</li> <li>2. Clean the rolling brush and the bearing thoroughly</li> </ol>
Battery doesn't hold a charger	<ol style="list-style-type: none"> <li>1. Check if the plug has been inserted already</li> <li>2. Check if the socket is useful</li> </ol>

## ※Specifications:

Power supply	Input 100-240V~50-60Hz (Charger)
Power supply method	Rechargeable type ( lithium ion battery,22.2V --- )
Electric power consumption	While charging : Approx. 11.7W; After charging : Approx. 0W
Continuous operation time	Low: Approx. 40 mins High: Approx. 15 mins
Dust collecting capacity	0.5L
Charging time	4-5 hrs
Weight(Suction head,pipe, base unit and battery included)	2.7kg
Weight(Charger)	88g
Base unit dimensions	255mm W × 1040mm H × 220mm D
Charger dimensions	51mm W × 36mm H × 77mm D
Cord length (Charger)	180cm

**SHARP**

SHARP CORPORATION